

# AVANT<sup>®</sup>

## 300S SERIES

Operator's Manual  
2005-

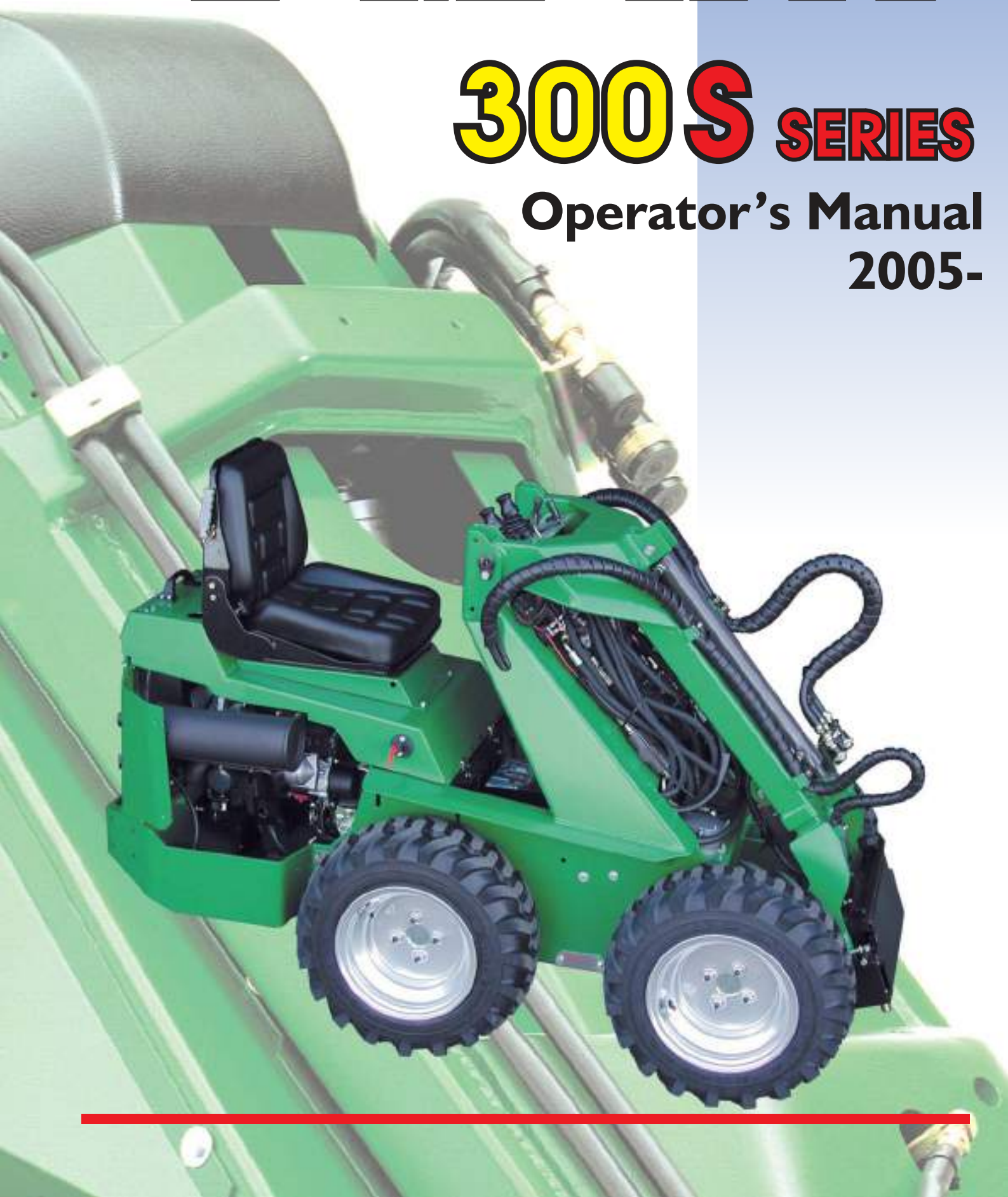

# TABLE OF CONTENTS

INTRODUCTION .....	3
AVANT 300S SERIES WARRANTY .....	3
EC DECLARATION OF CONFORMITY .....	4
HOW TO WORK SAFELY .....	5
DECAL LOCATIONS .....	6
MAIN PARTS OF THE LOADER .....	7
TECHNICAL SPECIFICATION .....	8
TECHNICAL SPECIFICATION, ENGINES .....	9
LOAD DIAGRAM .....	10
CONTROLS .....	11
STARTING THE ENGINE .....	14
STOPPING THE ENGINE .....	15
DRIVE CONTROL .....	15
DOUBLE SPEED FUNCTION .....	16
USING THE AUXILIARY HYDRAULICS .....	16
COUPLING THE ATTACHMENTS .....	17
300S SERIES SERVICE TABLE .....	18
SAFETY INSTRUCTIONS FOR MAINTENANCE .....	19
MAINTENANCE INSTRUCTIONS .....	20
REFUELING .....	21
FILTER LOCATION .....	22
FILTER TABLE .....	22
GREASING POINTS 300S SERIES .....	22
TROUBLESHOOTING .....	23
ATTACHMENT LISTING .....	24

## **INTRODUCTION**

**AVANT TECNO OY** wants to thank you for purchasing an **AVANT** loader. It is the result of Avant's long experience in design and manufacturing of compact loaders.

We ask you that you read and understand the contents of this manual completely before operating the loader. This will improve your operating and maintenance efficiency, help avoid breakdowns and damage and extend your machine's life.

Contact your local **AVANT** dealer for any questions, service, spare parts or about any problems that may occur with the operation of your machine.

## **AVANT 300S SERIES WARRANTY**

This warranty specifically applies to the **AVANT 300S** series loaders only and not to any attachments used with this product.

Any repairs or modifications performed without the prior authorisation of **AVANT Tecno Oy** will cancel this warranty.

During the first year of operation or the first 750 hours (whichever is the soonest) **AVANT Tecno Oy** warrants to replace any part or repair any defect which may occur, subject to the terms detailed below:

- 1) The product has received regular maintenance in accordance with schedules given by the manufacturer.
- 2) Any damage caused by operation in a negligent manner or exceeding the approved specifications detailed in this manual is excluded.
- 3) **AVANT Tecno Oy** accepts no responsibility for interruption to working or any other consequential losses resulting from any failure of the product.
- 4) Only **AVANT Tecno Oy** approved replacement or original quality parts shall be used during routine maintenance.
- 5) Any damage caused by the use of incorrect fuel, lubricants, cooling liquid or cleaning solvents is excluded.
- 6) The Avant Warranty excludes any consumable parts (e.g. tyres, spark plugs, batteries, filters, belts etc.) except where it can be clearly shown that these parts were defective on original supply.
- 7) Any damage caused resulting from the use of attachments not approved for use with this product is excluded.
- 8) In the event a fault occurs which is attributable to manufacturing or assembly defect you should arrange to return your **AVANT** to your authorised dealer for repair. Travel and freight costs are excluded.

## **IDENTIFICATION OF THE LOADER**

Write down the following information about your loader, it will help you when ordering parts etc.

1. Model: **AVANT** \_\_\_\_\_ Purchase date: \_\_\_\_\_
2. Serial number: \_\_\_\_\_
3. Engine serial number: \_\_\_\_\_

The serial number and model of the loader are printed on the manufacturer's plate which is located in the footwell (decal no. 8, see page 6). Location of engine serial number can be found in the operating manual of the engine.

**EC DECLARATION OF CONFORMITY FOR MACHINERY**

Manufacturer: AVANT TECNO OY

Address: Ylötie 1, 33470 YLÖJÄRVI, FINLAND

We hereby declare that the machines listed below conform to EC Directives: 98/37/EC (Machinery), 89/336/EEC (EMC) and 2000/14/EC (Noise Emission).

Category: EARTH-MOVING MACHINERY/LOADERS/COMPACT

Models: AVANT 313S, 314S, 320S and 320S+

Ylöjärvi, Finland, 07.01.2003

**AVANT TECNO OY**  
  
Risto Käkela  
Managing Director

## HOW TO WORK SAFELY

An incorrect or careless operation of the loader may be the origin of a serious accident. Before putting the machine into operation, familiarise yourself with the use of the machine and read and understand this Operator's Manual as well as the safety instructions.

### **THIS SYMBOL INDICATES THE IMPORTANT SAFETY FACTORS.**



Understand the limitations of speed, braking, steering and stability as well as loading capacity of the machine before starting operation.

If you have no previous experience of the machine, make sure to do all testing at a safe and open place with no persons in the area of operation.

## SAFETY INSTRUCTIONS

-  Never use the loader without instructions. Read loader signs (decals), and this manual.
-  Start the operation slowly and carefully.
-  Do not wear loose clothing, long uncovered hair or jewelry near machine.
-  When driving be comfortably seated in the driver's seat, keep your feet in their proper place in the footwell and both hands on the control levers.
-  Operate the control levers and the lever of auxiliary hydraulics only when sitting in the driver's seat.
-  Operate the control levers with ease and without hesitation.
-  When coupling the attachment, make sure that the locking pins lock in positively.
-  Never put any part of the body or let anyone go under the lifted boom.
-  Do not transport persons in the bucket. The machine is not designed to lift or to transport persons.
-  Keep hands, feet and clothing away from any moving part and/or hydraulic cylinder.
-  Never carry passengers. Keep other bystanders away from the work area.
-  Drive slowly on uneven terrains. Watch out for ditches, manholes and steep gradients.
-  Do not drive on too steep a gradient. Load, unload, and turn on flat level ground.
-  Make sure that the ventilation is sufficient when working indoors or otherwise confined area.
-  Do not use loader in an atmosphere with explosive dust or gases or where exhaust can contact flammable material, explosion or fire can result.



**Do not transport the load with the boom lifted.** Always carry bucket or attachment as low as possible, and put the load down whenever you leave the machine.



When lifting or lowering the load, do not operate the boom control lever abruptly. Turn the lever smoothly and with care.



Do not exceed rated operating capacity - follow the load diagrams.



Do not park the machine on a surface with a gradient. Should this be necessary, use the parking brake and preferably turn the machine sideways and put down the bucket. If needed, use chocks behind the wheels.



Before leaving driver's seat:

- Lower the loader boom
- Place attachment flat on ground
- Stop the engine, remove the key
- Engage the parking brake



Never perform any maintenance or repair operation when the engine is running.



Stop and cool the engine before adding fuel.



Never use ether or starting fluid on diesel engines with glow plugs. Use only starting aids as approved by engine manufacturer.



Keep the engine area clean of flammable materials.



Wear eye protection when servicing, and hard hat or other protective equipment as needed.



When connecting a booster battery for "jump" start, always make last connection (negative cable) to engine, never at battery. When removing the "jump" start cable, always remove the negative cable (-) from engine first.



Never charge a frozen battery.



Lead acid batteries produce flammable and explosive gases. Keep arcs, sparks, flames and lighted tobacco away from battery.



Battery acid causes severe burns. In case of acid contact, wash immediately with water for several minutes and get medical attention in case of eye contact.



Use a piece of cardboard to check for hydraulic leaks. Leaking fluids under pressure can enter the skin and cause serious injury. Medical attention is required if hydraulic or other fluids contact skin.



Never modify the loader or add attachments not approved by AVANT Tecno Oy.



**Do not smoke** during refueling or driving.



**Read this Operator's Manual carefully, especially if you are unfamiliar with the safe use and operation of the machine.**

## DECAL LOCATIONS

The following decals and signs should always be installed on the loader. If any of these decals has been removed or is unreadable it should be replaced without delay.

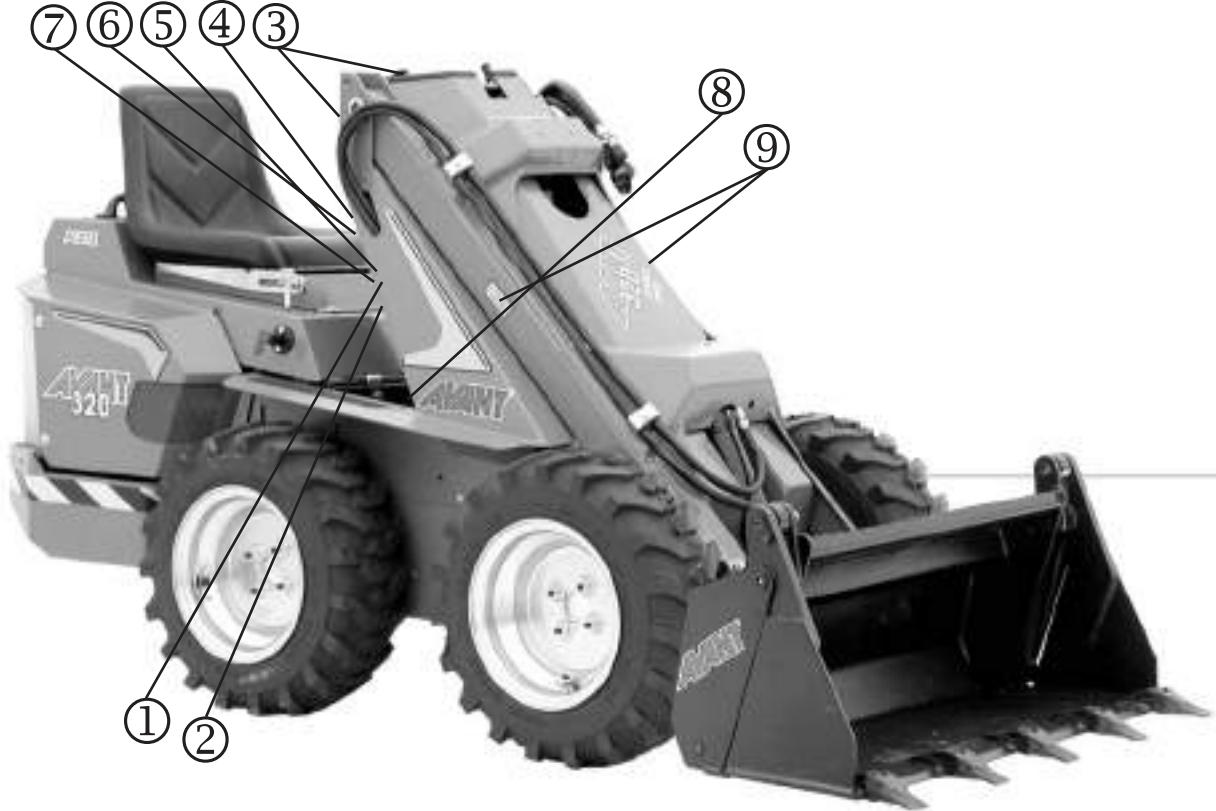

## MAIN PARTS OF THE LOADER

Following picture shows the main parts of the loader:

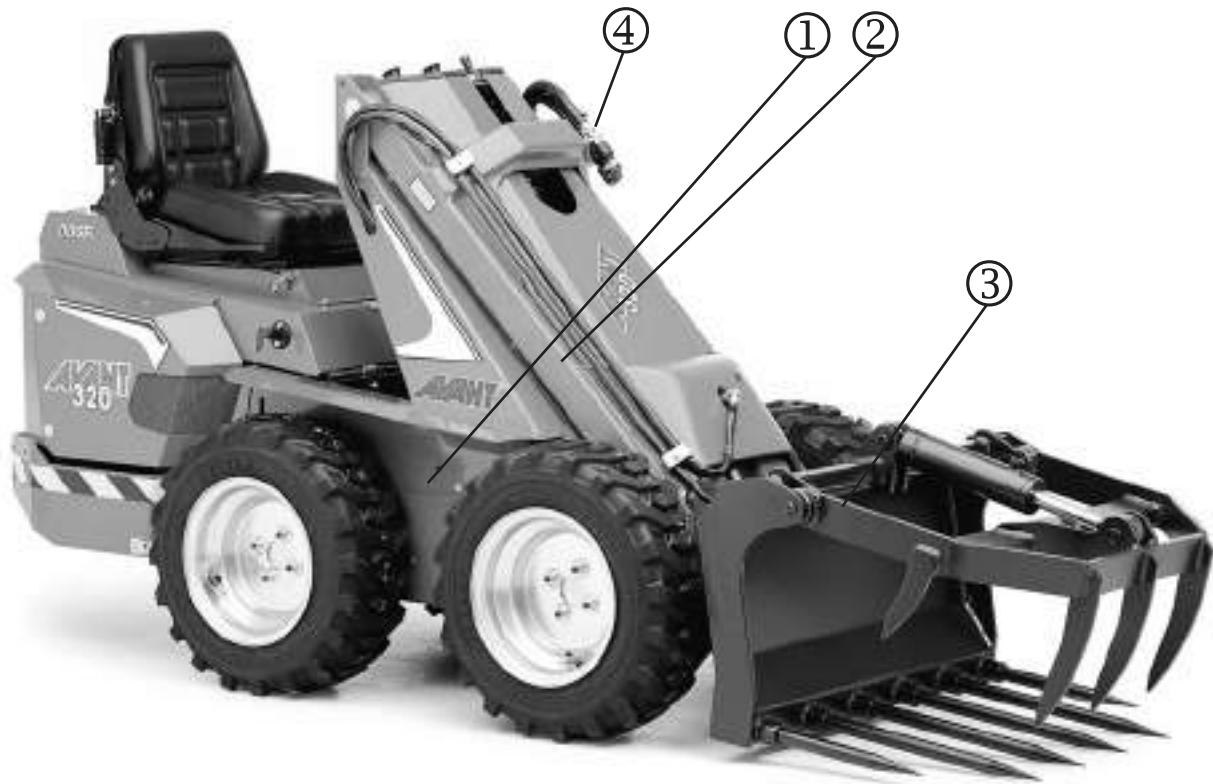

### ① Frame

The machine has a rigid frame, on which all the hydraulic components, engine, control valves, loader boom, wheels etc. are mounted.

### ② Loader boom

Loader boom is mounted on the front frame with two pivot pins. The attachment coupling plate is mounted on the lower end of the boom. There are two types of booms: standard boom with fixed length and the optional telescopic boom which extends 500 mm hydraulically.

### ③ Attachment coupling plate

Attachments are mounted on the attachment coupling plate.

### ④ Auxiliary hydraulics outlet

The hydraulic hoses of hydraulically operated attachments are mounted on this outlet with quick couplers. The outlet is double acting: it has two pressure lines and one return line. It is also possible to install an auxiliary hydraulics outlet in the rear of the machine (optional extra).

## ROPS AND FOPS (Option)

### I. ROPS frame

- ROPS frame complies with the ISO 3471 / SAE J1040 standard. Total machine height with ROPS frame is 1990 mm.

### I. FOPS canopy, mounts on the ROPS

- FOPS safety canopy exceeds the ISO 3449 Level I / SAE J1043 FOPS criteria. Total machine height with FOPS is 2050 mm.



## TECHNICAL SPECIFICATION

Model	AVANT 313S	AVANT 314S	AVANT 320S	AVANT 320S+
Length	1680 mm	1950 mm	1950 mm	1950 mm
Width	790-1050 mm (depending on tyre size)	790-1050 mm (depending on tyre size)	790-1050 mm (depending on tyre size)	790-1050 mm (depending on tyre size)
Standard tyre size	5x10 TR	23*8.50-12	23*8.50-12	23*8.50-12
Width	940 mm	1020 mm	1020 mm	1020 mm
Height	1200 mm	1250 mm	1250 mm	1250 mm
Axle width	795 mm	795 mm	795 mm	795 mm
Ground clearance	206 mm	206 mm	206 mm	206 mm
Weight	530 kg	610 kg	720 kg	720 kg
Drive speed:				
Single speed model	0 – 5 km/h	0 – 5 km/h	–	–
Double speed model	0 – 9 km/h	0 – 9 km/h	0 – 9 km/h	0 – 9 km/h
Drive hydraulics	hydraulic four wheel drive		hydraulic four wheel drive	
Auxiliary hydraulics flow and pressure	28 l/min single pump, 22,5 + 22,5 l/min double pump, 175 bar		22,5+22,5 l/min 200 bar	22,5+22,5 l/min 220 bar
Turning radius	same as the length of the machine	same as the length of the machine	same as the length of the machine	same as the length of the machine
Lifting height with standard boom	2100 mm	2100 mm	2100 mm	2100 mm
Lifting height with telescopic boom (Option)	2400 mm	2400 mm	2400 mm	2400 mm
Max. pulling force	6500 N	6500 N	7700 N	10 000 N
Max. lifting capacity (hydr.)	750 daN	750 daN	850 daN	880 daN
Tipping load*)	600 kg	650 kg	700 kg	700 kg
Engine	Honda GX 390 petrol	Kubota Z 482 diesel	Kubota D 722 diesel	Kubota D 722 diesel
Engine output	10 kW (13 hp)	10,5 kw (14 hp)	14 kW (20 hp)	14 kW (20 hp)

\*) with standard lift arm, 80 kg driver and 30 kg extra back weight, on flat even surface



**TECHNICAL SPECIFICATION, ENGINES**

<b>Engine type</b>	<b>Honda GX390 (petrol)</b>	<b>Kubota Z482 (diesel)</b>	<b>Kubota D 722 (diesel)</b>
Function	4 stroke	4 stroke	4 stroke
Cooling system	air	water	water
Number of cylinders	1	2	3
Starter	electric / manual	electric	electric
Bore * stroke	88 * 64 mm	67 * 68 mm	67 * 68 mm
Displacement	389 cm <sup>3</sup>	479 cm <sup>3</sup>	719 cm <sup>3</sup>
Max. output	10 kW (13 hp)	10,5 kW (14 hp)	14 kW (20 hp)
Fuel	petrol min. 92 oct.	diesel	diesel
Fuel tank capacity	6,5 l	18 l	18 l
Engine oil capacity	1,1 l	2,5 l	3,8 l
Engine oil type	API SE	API CC	API CC
Viscosity	SAE 10W-30	SAE 10W-30	SAE 10W-30
Valve clearance, suction	0,15 mm	0,145 – 0,185 mm	0,145 – 0,185 mm
Valve clearance, exhaust	0,20 mm	0,145 – 0,185 mm	0,145 – 0,185 mm
Sound pressure level L <sub>PA</sub>	84 dB (A)	87 dB (A)	88 dB (A)
Sound power level L <sub>WA</sub>	100 dB (A)	102 dB (A)	101 dB(A)

## LOAD DIAGRAM

The lifting capacity of the loader is limited by the possibility of tipping around the front axle. The diagram below shows the tipping loads and max. allowed loads in different loading situations on an even level surface.

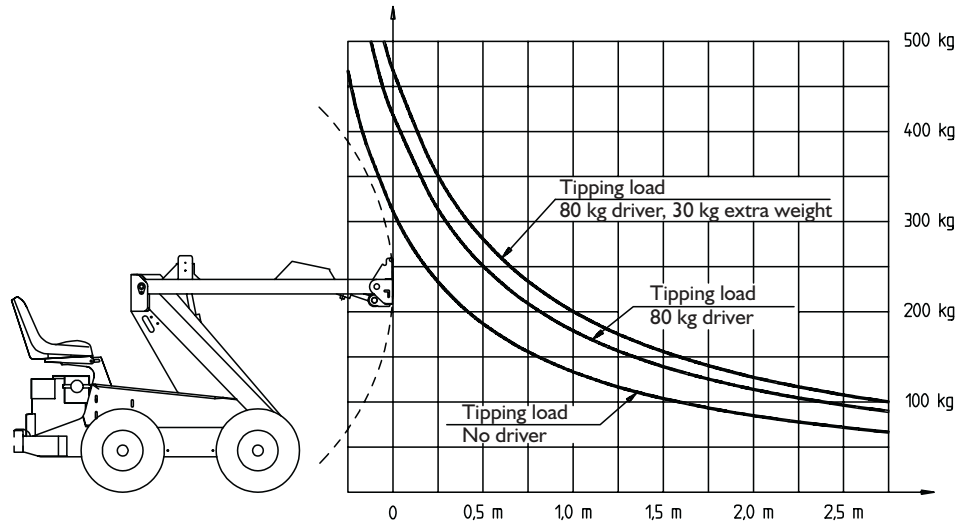

**AVANT 313S load diagram**

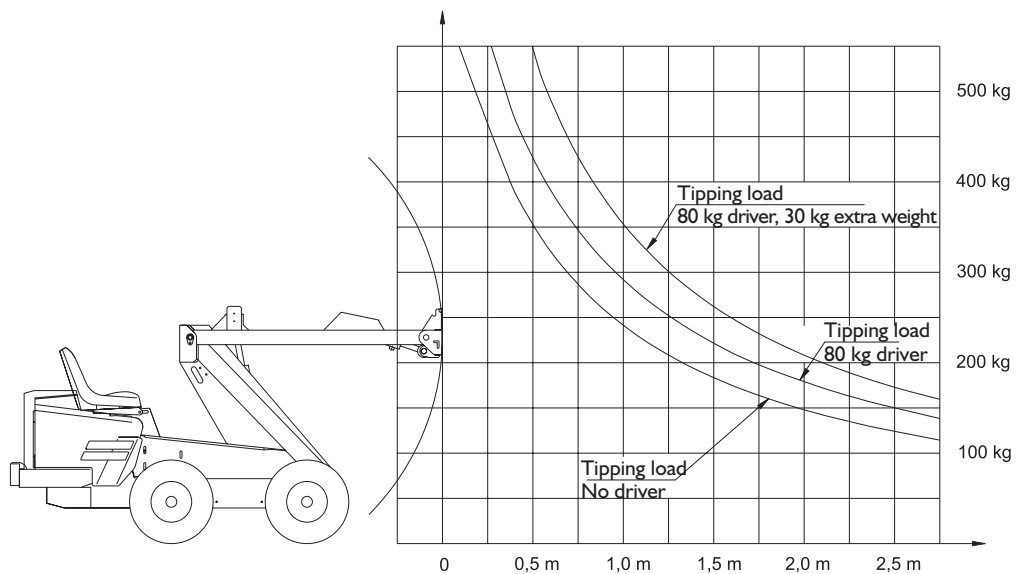

**AVANT 314S/320S /320S+ load diagram**

The diagrams can be interpreted as follows:

- If the load is 25 cm in front of the attachment coupling plate, the max. load for the model **313S** with 13 hp petrol engine is 310 kg for the loader with a driver weighing 80 kg. For the **314S** model the max. load is 400 kg, for the **320S** and **320S+** models the max. load is 460 kg.
- If the load is still 25 cm in front of the attachment coupling plate and a rear weight of 30 kg is added, the max. load increases to 350 kg for the **313S** petrol model. For the **314S** diesel model the max. load is 440 kg, and for the **320S** and **320S+** models the max. load is 510 kg.

**CAUTION!** In practice the safe working load is 70 % of the diagram values. Do not load the loader with heavier loads than this.



**ALWAYS PUT DOWN THE LOAD BEFORE LEAVING THE MACHINE.**

## OPERATING CONTROLS

Following picture shows the location of operating controls. The location and function of controls may be slightly different in different models, see following pages.

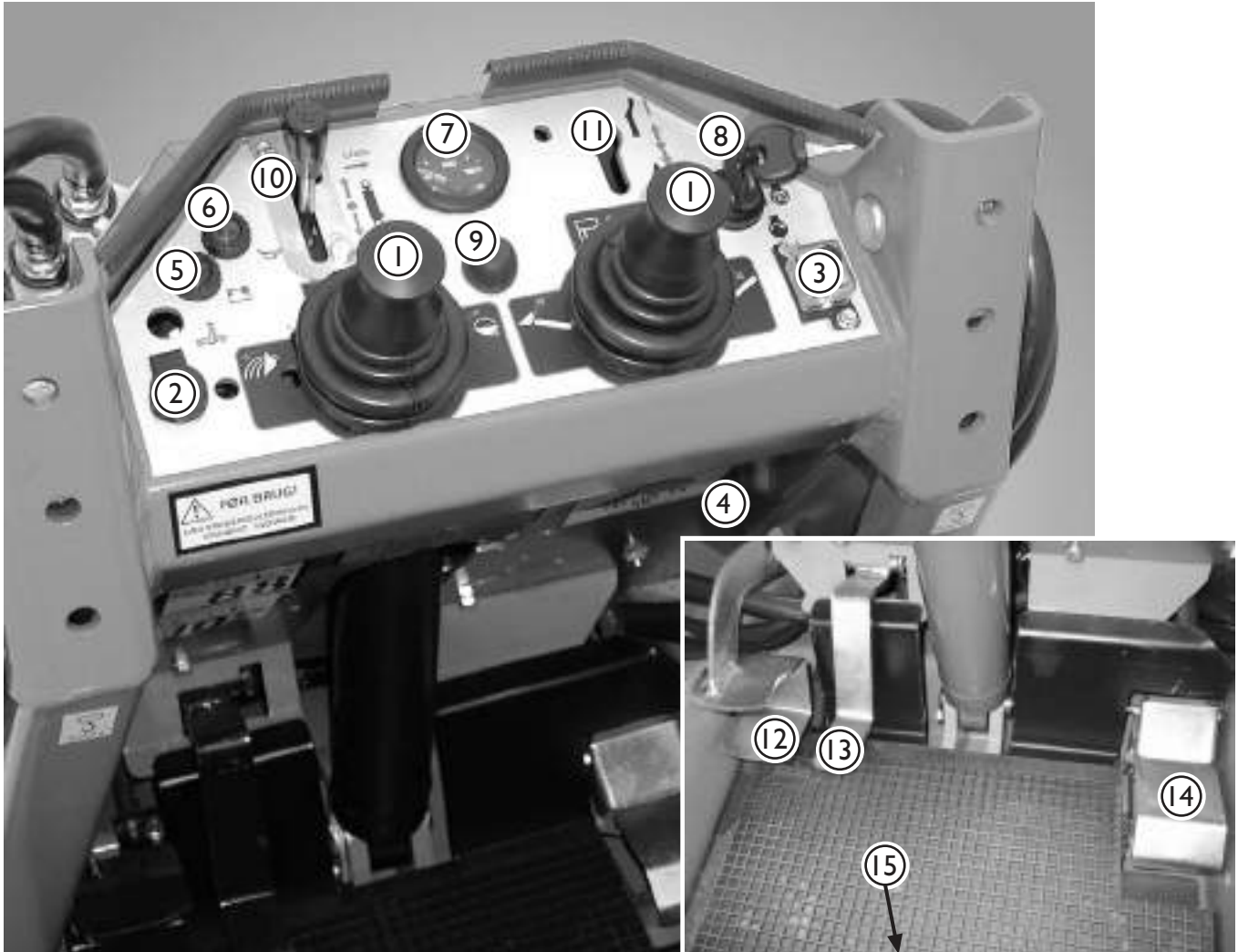

- |  |   |
|--|---|
| 1. Control levers for drive and boom & tilt          | 10. Auxiliary hydraulics control lever (models 313S, 314S and 320S)   |
| 2. 12V outlet  | 11. Control lever for telescopic boom (Optional extra)                |
| 3. Fuse box (2 pcs. fuses)                           | 12. Auxiliary hydraulics control pedal (models 313S, 314S and 320S)   |
| 4. Hour meter  | 13. Double speed control pedal (models 313S, 314S and 320S)           |
| 5. Charge indicator                                  | 14. Throttle pedal  |
| 6. Oil pressure indicator                            | 15. Parking brake handle (turn 180° left to engage the parking brake) |
| 7. Thermometer                                       |   |
| 8. Ignition switch (Positions: Off, On, Glow, Start) |   |
| 9. Signal horn                                       |   |

## CONTROL OF LOADER BOOM, ATTACHMENTS AND OTHER FUNCTIONS

The control levers for driving, boom and bucket control, auxiliary hydraulics and telescopic boom (option) are mounted on the dashboard in front of the operator. On the following are the explanations for these functions.

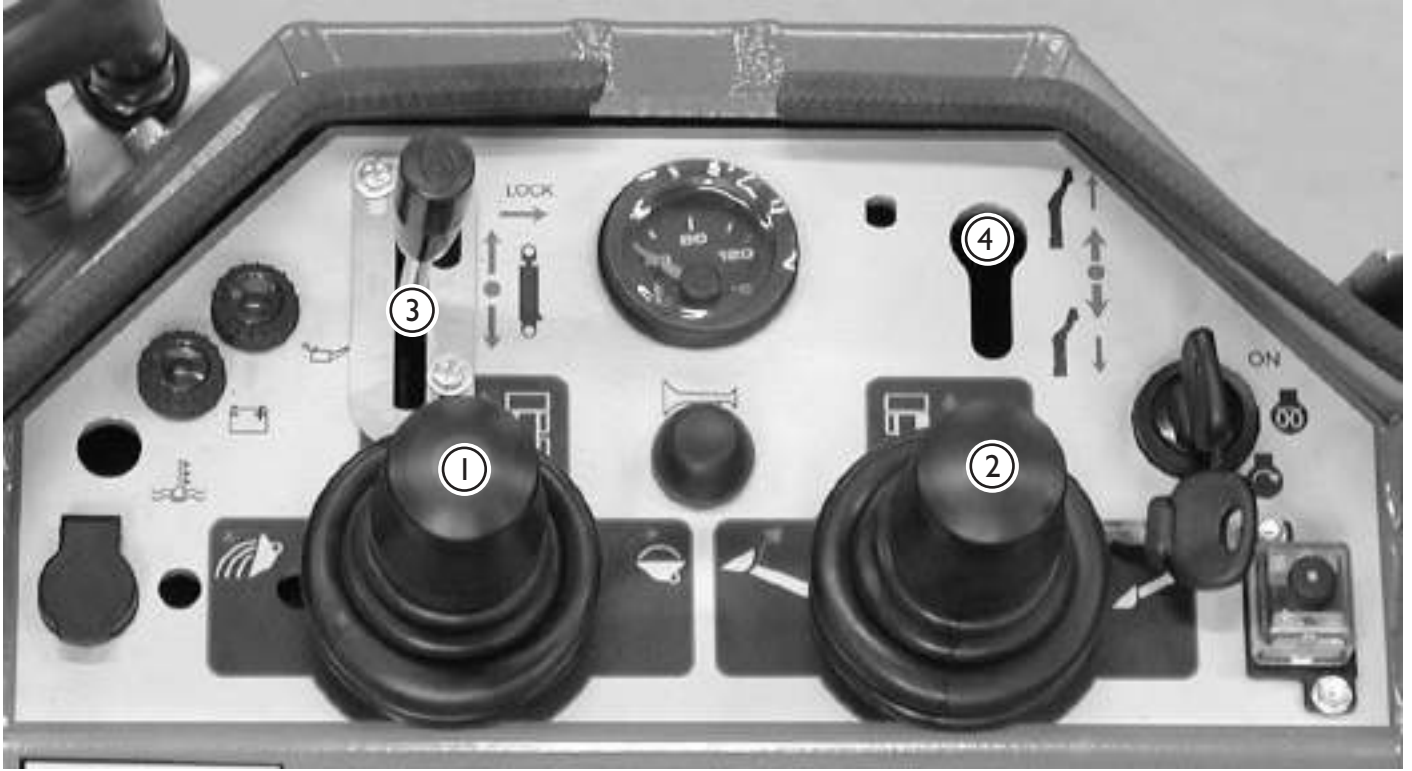

### 1. Drive (left side wheels) and bucket tilt control lever

- Push forward: The left side wheels turn forward (forward drive, left side wheels)
- Pull backward: The left side wheels turn backward (reverse drive, left side wheels)
- Push left to lower the tip of the bucket (emptying)
- Push right to raise the tip of the bucket (filling)

### 2. Drive (right side wheels) and boom control lever

- Push forward: The right side wheels turn forward (forward drive, right side wheels)
- Pull backward: The right side wheels turn backward (reverse drive, right side wheels)
- Push left to lift the boom
- Push right to lower the boom

### 3. Control lever of auxiliary hydraulics (models 313S, 314S and 320S)

- Push forward carefully to find out which way the hydraulic attachment is functioning.
- Pull backward: The attachment operates in opposite direction
- Lock position: Continuous flow (for rotary broom, backhoe etc.)

#### Model 320S+ : Control lever of pump selection

- Lever in the "back" position ("turtle"): flow of one pump selected. Drive with lower speed - simultaneous operation of auxiliary hydraulics with one pump is possible
- Lever in the "front" position ("rabbit"): flow of both pumps selected. Drive with double speed, simultaneous operation of auxiliary hydraulics is not possible. Operation of auxiliary hydraulics with flow of both pumps, simultaneous driving is not possible

### 4. Control lever of telescopic boom (Optional extra)

- Push forward to extend the boom
- Pull backward to retract the boom

## CONTROLS IN THE FOOTWELL

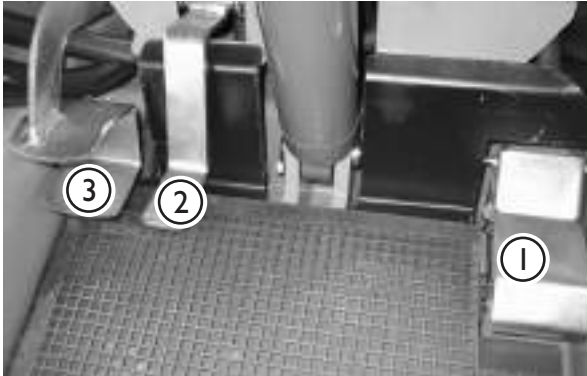

The picture on the left shows the controls located in the footwell for models **313S, 314S** and **320S**:

- 1. Throttle pedal:** Controls engine revs
- 2. Double speed pedal:** Press the pedal down to engage double speed function
- 3. Auxiliary hydraulics pedal:** Controls the auxiliary hydraulics function. By pressing this pedal down the attachment operates in one direction, by lifting the pedal upward the attachment operates in reversed direction.  
**ATTENTION!** Auxiliary hydraulics can also be operated with the control lever on the dashboard, see previous page.

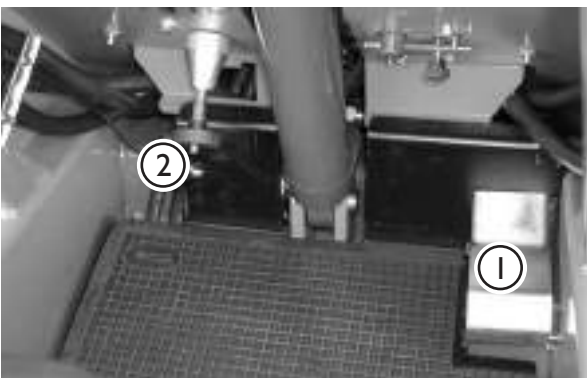

The picture on the left shows the controls located in the footwell for model **320S+**

- 1. Throttle pedal:** Controls engine revs
- 2. Auxiliary hydraulics control lever:** Controls the auxiliary hydraulics function. By pressing this lever down the attachment operates in one direction, by lifting the lever upward the attachment operates in reversed direction.  
**ATTENTION:** The black plastic screw on the control lever adjusts the movements and locking of the lever. When the screw is not tightened the lever moves up and down and locks into locking position (continuous flow for certain attachments like rotary broom, backhoe etc.) If the locking

position is not desired – e.g. when working with a silage fork - tighten the screw until the lever does not lock but moves up and down and remains in the neutral position when not operated.

## TELESCOPIC BOOM (Optional extra)

The optional telescopic boom gives more lifting height and outreach. Length of the telescope is 500 mm and the additional lifting height is 300 mm. Telescopic boom is operated with the control lever no. 4 on the control panel (see previous page).



## SUSPENSION SEAT (Option)



The optional suspension seat has the following adjustments:

- 1. Suspension adjustment**
  - by turning the lever clockwise suspension gets harder, by turning it counterclockwise the suspension gets softer
- 2. Angle of the back rest**
  - the angle of the back rest can be adjusted by turning the knob
- 3. Seat position**
  - the distance of the seat from the steering wheel can be adjusted with the lever which is located under the front edge of the seat

Suspension seat can be equipped with a seat belt (option).

## STARTING THE ENGINE



### **Petrol engine (Avant 313S, see also Honda engine Owner's Manual)**

- Turn the battery disconnect switch to ON

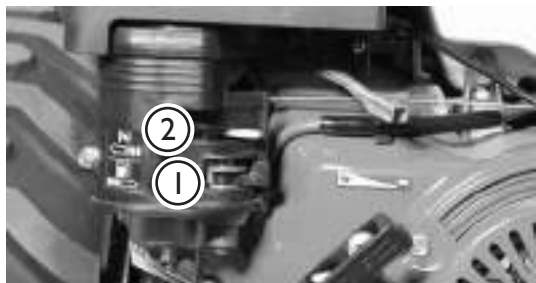

- Turn the fuel valve to the on ON position ① (on the left side of the engine, see Honda Owner's Manual)
- Move the choke lever to the left to CLOSE position ② (above fuel valve, see Honda Owner's Manual)

**NOTE:** Do not use the choke if the engine is warm or the air temperature is high



- Turn the ignition key to the right until engine starts, then let the key return to ON position
- Reduce choke (move choke lever to the right) as soon as engine has started, move completely to the right when engine has warmed up



### **Diesel engine (Avant 314S, 320S and 320S+)**

- Turn the battery disconnect switch to ON



- Turn the ignition key to the right, keep the ignition key in this position for approx. 10 seconds, depending on the ambient temperature.

**ATTENTION** There is no glow plug indicator lamp – do not glow for more than 10 seconds at a time.

- Turn the ignition key further to the right until the engine starts, then let the key return to ON position



**NOTICE!** The engine cannot start if the auxiliary hydraulics control lever is in locking position or the pump selection lever (on model 320S+) is in the position „2-pump“ (when the ambient temperature is low)

## **STOPPING THE ENGINE**

- Turn the ignition key to the OFF position (to the left)
- Turn the power off with the battery disconnect switch

## **DRIVE CONTROL**

Start the engine as explained on previous pages. When starting the engine do not touch any control lever.

After starting the engine take a firm grip on the control levers (see picture on the right). It is important to use exactly this grip, it gives you the best possible feel on the levers and control on the machine. This way you will be able to control the machine smoothly and securely right from the start.

### **Driving forward**

Select first moderate engine revs by pressing the throttle pedal and push carefully both drive control levers forward until they are completely in the forward position. The machine starts to go straight forward. Do some training by repeating this movement so that the machine starts smoothly – if you operate the control levers abruptly the movements will be jerky. Drive speed can be increased with the throttle pedal. The machine will stop as soon as one allows the levers to return to center (neutral) position.

### **Reverse driving**

Reverse driving happens exactly the same way as driving forward, except that the drive control levers are now being pulled backwards. Drive speed can be increased with the throttle pedal. The machine will stop as soon as one allows the levers to return to center (neutral) position.

### **Turning**

Turning of the machine is based on the skid steer principle. When you want to turn the machine to a direction, push/pull the drive control lever less on the inner curve side. By doing this the inner wheels brake and consequently the machine turns. If you want to turn the machine on the spot, push one side drive control lever and pull the other side control lever to the extreme end position.

### **Loader control**

Loader boom and bucket tilt functions are operated



with the same multi-function levers as drive, by turning them sideways.

### **Right side lever is for boom control**

- Push right to lower the boom
- Push left to lift the boom

### **Left side lever is for attachment (e.g. bucket) tilt control**

- Push right to lower the tip of the bucket
- Push left to raise the tip of the bucket

**Memory helper:** By turning both levers inwards both boom and tip of bucket rise.

## DOUBLE SPEED PEDAL



Models **313S**, **314S** and **320S** have a double speed function (optional extra) which is operated with a pedal in the footwell (see picture). Double speed can be engaged either before starting driving or while driving. It can also be disengaged at any time during driving or after the driving by lifting the foot off the pedal.

Double speed function doubles the driving speed. It is intended for long transitions, where higher drive speed can safely be used.

**NOTICE!** When using double speed the oil flow to the drive

hydraulic motors is bigger and therefore the pulling force is smaller. When turning use the lower speed in order that the machine turns more easily.

Double speed on model **320S+**: On **320S+** double speed is selected with the pump selection lever on the left on the dashboard. Push the lever forward to engage the double speed function.

**ATTENTION!** Do not start to drive with the machine before you have read and understood the instructions in this Operator's Manual. If you are uncertain of the conduct of the machine please contact your **AVANT** dealer for instructions.



**NEVER TIP OVER THE LOADER. NEVER USE A HIGH DRIVE SPEED WHEN TURNING.**

In particular: when the loader boom is up the stability of the machine is much weaker when turning.



**WHEN DRIVING, ALWAYS KEEP THE LOADER BOOM AS LOW AS POSSIBLE.**

Risk of tipping over increases considerably when there is a heavy load on the loader (a heavy attachment or a big load in the bucket) and the boom is up when driving.



**ALWAYS REMEMBER – SAFETY FIRST.**



**TEST ALL THE FUNCTIONS OF THE LOADER AT AN OPEN AND SAFE PLACE.**



**MAKE SURE THAT THERE ARE NO PERSONS IN THE OPERATING AREA OF THE MACHINE.**

## USING THE AUXILIARY HYDRAULICS

On models **313S**, **314S** and **320S** auxiliary hydraulics (hydraulically operated attachments) are controlled either with the control lever no. 3 on the dashboard or with the pedal no. 3 on the left in the footwell (see pages 12 and 13). The lever can be locked in the up right position, in case continuous oil flow for the attachment is required (e.g. with backhoe, rotary broom etc.).



On model **320S+** auxiliary hydraulics are controlled with the lever no. 2 in the footwell left (see page 13).

When pulling the auxiliary hydraulics control lever upwards it locks into the locking position. This facilitates the use of those attachments that require constant oil flow, the rotary brush for example. If the lever must not lock into the locking position (e.g. with the silage fork), tighten the black round screw in the lever so that the spring load always brings the lever back in the middle position.

On **320S+** the oil flow to auxiliary hydraulics depends on the position of the pump selection lever on the left on the dashboard. When the pump selection lever is in the "back" position, the flow of one pump (22,5 l/min) is selected for auxiliary hydraulics and one can drive the machine on the lower speed at the same time (e.g. when operating a rotary broom). When the selection lever is in the "front" position, both pumps are coupled and one can either operate the auxiliary hydraulics with the flow of both pumps (45 l/min) or drive the machine on double speed, but not both.



**NOTICE! THE ENGINE CANNOT START IF THE AUXILIARY HYDRAULICS CONTROL LEVER IS IN THE LOCKING POSITION.**



**THE OPERATING DIRECTION OF THE ATTACHMENT DEPENDS ON THE COUPLING OF THE ATTACHMENT HOSES. MAKE SURE THAT THERE ARE NO PERSONS IN THE DANGER AREA WHEN TESTING THE OPERATING DIRECTIONS. CHANGE THE COUPLING OF THE HOSES IF NECESSARY.**



**COUPLING THE ATTACHMENTS**

Coupling of the attachments into the attachment coupling plate happens as follows:

**Stage 1:**

- Lift up the two locking pins on either side of the attachment coupling plate and turn them backward so that they remain in the locked up position
- Make sure that the pins remain in the up position, otherwise you cannot couple the attachment properly!

**Stage 2:**

- Turn the attachment coupling plate with the tilt movement so that the upper edge of the plate leans forward.
- Drive the loader into the attachment

**Stage 3:**

- Lift the boom a little so that the attachment lifts off of the ground
- Pull the boom control lever to the left so that the lower edge of the attachment coupling plate turns into the attachment

**Stage 4:**

- Pull the boom control lever more to the left so that attachment coupling plate turns more and the bolts on the boom push the pins down in the holes of the attachment.
- **CAUTION! Make sure that the pins lock properly down in the holes of the attachment.**

**Stage 5:**

- If the attachment is equipped with hydraulic hoses, make sure to connect the hoses in the quick couplings on the loader
- Engine must be stopped when connecting the hoses. Before connecting the hoses move the auxiliary hydraulics control lever in both directions a couple of times in order to release eventual back pressure.
- Additional information about the coupling is provided in the instruction manual of the attachment.
- **NOTICE! When fitting an attachment, make sure that the hydraulic hoses are not overstretched and are not in a position where they can be trapped during the operation of the machine and attachment.**

## MAINTENANCE SCHEDULE

Following table shows the maintenance and service points and intervals. There are more detailed instructions about each service operation, in numerical order, on the following pages.

<b>LOADER</b>	Every day	Every week	After 25 h	After 50 h	Every 100 h	Every 200 h	Every 400 h	Every 500 h	Every 800 h	Every 1000 h	Every year
1. Clean the machine	■										
2. Check tyre pressure		●									
3. Check battery electrolyte level		●									
4. Check hydraulic oil level		●									
5. Change hydraulic oil filters				●		●					
6. Change hydraulic oil				●			●				
7. Check tightness of bolts, nuts and hydraulic fittings			●								
8. Check pressure of hydraulic system				■							●
9. Adjust pressure of hydraulic system				■							■
10. Grease the machine	■	●									
<b>PETROL ENGINE*)</b>											
11. Check engine oil level		●									
12. Change engine oil					●						
13. Clean air filter	■	●									
14. Clean fuel filter and sediment cup					●						
15. Clean spark arrester					●						
16. Change spark plug					●						
17. Change air cleaner element											●
18. Check and adjust valve clearances											●
<b>DIESEL ENGINE*)</b>											
19. Check engine oil level	●										
20. Change engine oil					●						
21. Clean air filter		●			●						
22. Clean fuel filter and sediment cup					●						
23. Check condition and tightness of alternator belt					●						●
24. Check water hoses and hose clamps						●					
25. Change engine oil filter						●					
26. Change fuel filter							●				
27. Clean fuel tank											●
28. Clean radiator cells	■							■			
29. Change coolant											●
30. Change air cleaner element					■						●
31. Check and adjust valve clearances									●		
32. Check opening pressure of nozzles										●	

● Maintenance operation

■ When necessary

\*) More specific engine maintenance instructions can be found in the owner's manual of the engine, supplied with the loader.

## **SAFETY INSTRUCTIONS FOR MAINTENANCE**



- ALWAYS REMEMBER SAFETY DURING MAINTENANCE**
- DO NOT PERFORM ANY SERVICE OPERATION WHEN THE ENGINE IS RUNNING**
- USE THE SERVICE SUPPORT ON THE BOOM CYLINDER**
- DO NOT GO UNDER UNSUPPORTED BOOM**
- DO NOT SMOKE DURING SERVICE OPERATIONS**
- BEWARE POSSIBLE HIGH PRESSURE IN HYDRAULIC CIRCUITS**

## **MOUNTING OF THE SERVICE SUPPORT**



Hydraulic oil tank is located on the front axle as a part of the front chassis, so in order to get to the dipstick and return oil filter the boom must be lifted and the front cover plate removed.

Make sure that the boom stays up by putting the service support on the lift cylinder piston rod.

The red service support is located behind the attachment coupling plate, fastened with a bolt



Make sure to secure the service support by locking it on the piston rod by the bolt

## **SAFETY INSTRUCTIONS WHEN HANDLING THE BATTERY**



- BATTERY CONTAINS CORROSIVE SULFURIC ACID.**
- AVOID CONTACT WITH SKIN OR CLOTHES. IF ELECTROLYTE GETS ON YOUR SKIN OR CLOTHES, FLUSH WITH A LOT OF WATER.**
- IN CASE OF CONTACT WITH EYES, FLUSH WITH A LOT OF WATER FOR AT LEAST 15 MINUTES AND CALL A DOCTOR IMMEDIATELY.**
- WHEN CHARGING THE BATTERY GIVES OFF POTENTIALLY EXPLOSIVE GASES – DO NOT SMOKE WHEN HANDLING THE BATTERY.**
- IN ORDER TO AVOID SPARK EMISSIONS ALWAYS DISCONNECT THE NEGATIVE (-) CABLE FIRST AND CONNECT IT LAST.**
- BEFORE CONNECTING THE BATTERY CABLES MAKE SURE THAT THE POLARITY IS CORRECT: FAULTY CONNECTION WILL SERIOUSLY DAMAGE THE ELECTRIC SYSTEM OF THE ENGINE.**

## 1. CLEANING THE LOADER

Cleanliness of the loader is not only a question of outer appearance. All surfaces, painted and others, will stay in better condition when they are cleaned regularly. A clean machine also lasts longer. A dirty machine will run hotter and will collect dirt into the air cleaner, which is likely to damage the engine. Pay special attention to the cleanliness of the engine, the oil tank cover, the engine compartment and the hydraulic pump compartment. The loader can be washed with a pressure washer.

## 2. TYRE PRESSURE

Correct tyre pressure means that the tyres last much longer. Wrong tyre pressure increases tyre wear and can be a safety risk when working with the loader.



Recommended tyre pressures are:

- 4.00 - 12 tyre 2.8 bar (40.6 PSI)
- 5.00 - 10 tyre 2.8 bar (40.6 PSI)
- 20\*8.00-10 tyre 2.8 bar (40.6 PSI)
- 23\*8.50-12 tyre 2.5 bar (36.3 PSI)

## 3. BATTERY CHECK

In order to secure the starting and safe operation the battery of the loader must be checked regularly. Checking the electrolyte level of the battery happens by opening the filler caps.



**ATTENTION!** Clean the battery before opening the caps so that dirt cannot get in the battery. Check also the contacts and clean if necessary.

## 4. HYDRAULIC OIL LEVEL

Hydraulic oil level can be checked with the dipstick in the filler. Oil level should be between the two marks in the dipstick. Refill when necessary. Clean the area before checking hydraulic oil level. Do not let any contaminants enter the hydraulic oil tank during this procedure.



## 5. CHANGING OF HYDRAULIC OIL FILTER

The hydraulic oil return filter is located on top of the hydraulic oil tank, under the cover. Take off the cover and replace the oil filter cartridge.

**Remember to use the service support.**



## 6. HYDRAULIC OIL CHANGE

When changing hydraulic oil, the oil can be removed with a suction pump or by opening the drain plug on the front of the frame, between the front drive motors. In both cases it is important to clean the magnetic drain plug.

Hydraulic oil capacity is 51 litres. Use ISO VG-46 certified mineral hydraulic oil (e.g. Shell Tellus TX oil). Use of synthetic hydraulic fluids is not allowed.

## 7. CHECK AND TIGHTENING OF BOLTS, NUTS AND FITTINGS

Check tightness of bolts, nuts and hydraulic fittings regularly.

**ATTENTION!** Tighten wheel nuts after first 5 operating hours. Check tightness of wheel nuts regularly. Wheel nuts shall first be to 120 Nm diagonally opposite and finally tightened to 140 Nm.

## 8. CHECKING THE HYDRAULIC SYSTEM PRESSURE

Correct pressure in hydraulic system is of vital importance. Too high pressure can seriously damage the hydraulic system. Too low pressure on the other hand means low performance: the capacity of the hydraulic system is not being used as it should.

Hydraulic pressure settings:

- **313S, 314S:** 175 bar
- **320S:** 210 bar (drive), 200 bar (aux. hydr.)
- **320S+:** 240 bar (drive), 200 bar (aux. hydr.)



## Measuring the hydraulic system pressure:

System pressure is measured from the female auxiliary hydraulics quick coupling, with full revs and by turning the aux. hydraulics control lever.

**ATTENTION!** It is recommended that pressures should only be checked and adjusted by a competent and experienced technician. Call your **AVANT** dealer if you need assistance.

## 9. ADJUSTING THE HYDRAULIC SYSTEM PRESSURE:

If the pressure of hydraulic system does not seem to be correct or pressure check indicates that the pressure is wrong, it can be adjusted.



On models **313S**, **314S** and **320S** pressure is adjusted from the pressure relief valve at the main control valve (see picture). Adjustment screw is under the cap, adjustment with hexagonal head key. On model **320S+** pressure for auxiliary hydraulics is adjusted from the pressure relief valve at the aux. hydraulics control valve (in the footwell, remove the front cover plate in order to get to the valve). Pressure for drive is adjusted from the pressure relief valve at the main control valve.



**NEVER EXCEED THE RECOMMENDED HYDRAULIC PRESSURE SETTINGS. EXCESSIVE HYDRAULIC PRESSURE WILL DAMAGE THE HYDRAULIC PUMPS, CYLINDERS, AND HYDRAULIC MOTORS.**



**WARRANTY DOES NOT COVER DAMAGES CAUSED BY EXCESSIVE HYDRAULIC PRESSURE.**

## 10. GREASING OF THE MACHINE

Greasing of pivot points is very important in order to avoid wear. Most of the greasing points are on the loader boom. There are 8 grease nipples altogether on a machine with standard boom and 14 grease nipples on a machine with telescopic boom. The picture on page 22 shows the location of grease nipples.

## 11.-18. SERVICE, PETROL ENGINE

**AVANT 313S** is equipped with the Honda GX390 petrol engine. Service and maintenance instructions for this engine can be found in the Honda Operator's Manual supplied with the loader.

## 19.-32. SERVICE, DIESEL ENGINE

**AVANT 314S** is equipped with the Kubota Z482 2 cylinder diesel engine, **320S** and **320S+** are equipped with the Kubota D722 3 cylinder diesel engine (see technical specification sheet for the engine type of each model). Service and maintenance instructions for the engines can be found in the Kubota Operator's Manual supplied with the loader.

## REFUELING

**Petrol engine:** Check fuel level and fill the tank if necessary. Never use petrol mixed with oil or unclean petrol. Use unleaded petrol only, see also Honda Owner's Manual.



**Diesel engine:** Check fuel level and fill the tank if necessary. Use diesel fuel only, in accordance with the instructions in the Kubota engine Operator's Manual. Use of other fuels is not allowed, because their quality and properties cannot be guaranteed. Make sure not to let the fuel tank get empty. Should this happen, refuel and restart – the engine is fitted with automatic fuel bleeding.



**DO NOT SPILL FUEL WHEN REFUELING. SHOULD THIS HAPPEN, WIPE THE FUEL AWAY IMMEDIATELY IN ORDER TO AVOID RISK OF FIRE.**



**ALWAYS STOP THE ENGINE BEFORE REFUELING. KEEP THE ENGINE AWAY FROM OPEN FIRE.**

## FILTERS

Following pictures and tables show the location and part numbers for the filters.

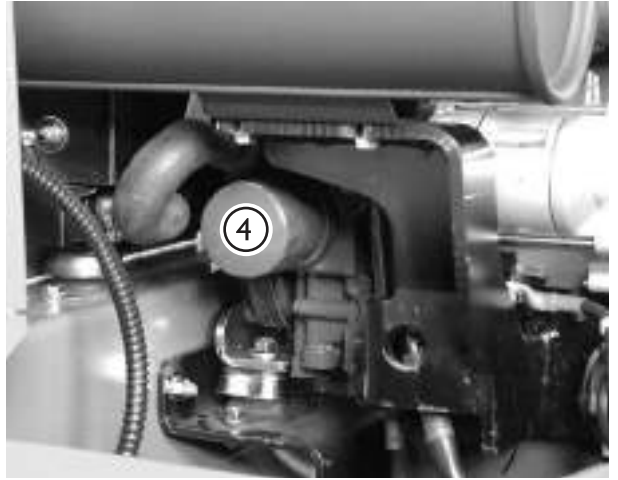
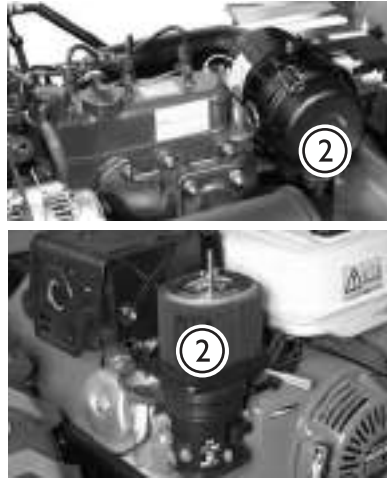

- 1. Fuel filter
- 2. Air filter
- 3. Hydraulic oil filter, return
- 4. Engine oil filter

A 44494	Filter kit 313S
64217	Air filter
74093	Hydraulic oil filter, return
64219	Spark plug

A 44495	Filter kit 314S, 320S and 320S+
64712	Air filter
64220	Fuel filter
64207	Engine oil filter
74093	Hydraulic oil filter, return



**ATTENTION!** On older **300S series** loaders with Kubota 14 hp or 20 hp diesel engine, manufactured prior to 08/2002, the air filter may be different (part no. 64212). When ordering filters always check the serial number and manufacturing date of your loader in order to get the correct filters.

## GREASING POINTS

Following pictures show the location of greasing points.

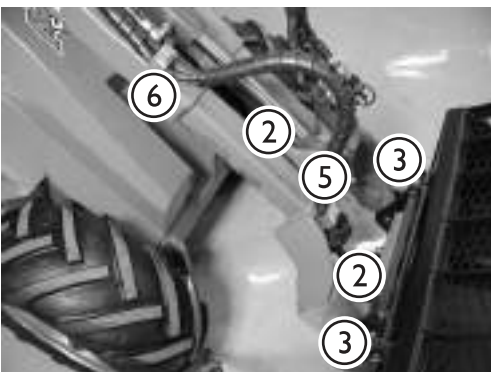
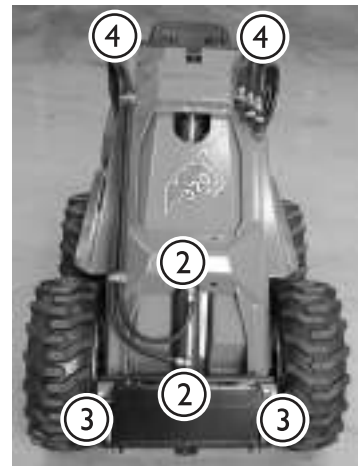

- 1. Lift cylinder, upper end.
- 2. Tilt cylinder, both ends
- 3. Shot bolts on attachment coupling plate
- 4. Pivot pins on loader boom
- 5. Telescopic cylinder, both ends
- 6. Telescopic boom

**TROUBLESHOOTING**

Following table shows the most common problems and the solutions to them. There are more instructions and troubleshooting advice concerning the engines in the Owner’s Manual of the engine (Honda or Kubota).

<b>Problem</b>	<b>Cause</b>	<b>Remedy</b>
Hydraulic attachment does not work when the auxiliary hydraulics control lever is moved	Attachment hoses are not coupled or they are coupled wrongly in the quick couplers.  Faulty or damaged quick couplers (will restrict or stop oil flow).	Make sure that the hoses are properly connected into the quick couplers, change the place of the hoses if necessary. Auxiliary hydraulics have double acting pressure couplers (female) and a return line (male coupler) Operating direction of the attachment depends on how the hoses are connected in the quick couplers. Replace quick couplers.
Engine does not start.	No fuel Auxiliary hydraulics control lever (lever no. 3, page 12) is in locking position.	Fill the tank and start the engine. Diesel engines have automatic fuel bleeding – just glow and restart. Turn the lever in center (neutral) position
Attachment hoses will not go into the quick couplers of the machine.	There is back pressure in the auxiliary hydraulics line.	Release the pressure by moving the auxiliary hydraulics control lever in both directions.
The machine moves after parking brake has been engaged.	The pins of the parking brake mechanism have not locked properly in the wheels.	Drive slowly forward or backward in order to lock the parking brake. When releasing the parking brake do this in opposite order.

## AVANT attachments

### **Basic attachments:**

General buckets  
Light material buckets  
High tip buckets  
4 in 1 buckets  
Skip bucket  
Angle blade  
Pallet fork  
Jib crane

### **Digging:**

Digger 140  
Backhoe 205  
Backhoe 220  
Backhoe 250  
Trencher

### **Contracting:**

Auger  
Hydraulic breaker  
Concrete mixer  
Vibrating plate

### **Agriculture:**

Silage fork  
Silage block cutter  
Grapple bucket  
Silage feeder bucket  
Grain dispenser  
Manure fork  
Carousel broom

### **Property maintenance:**

Rotary broom  
Rotary broom with collector box  
High pressure washer  
Tipping trailer  
Salt spreader  
Snow blower  
Snow broom

### **Landscaping:**

Lawn mower  
Flail mower  
Rotary hoe  
Stone burier  
Rotary harrow  
Ripper  
Leveler  
Wood chipper  
Log cutter/splitter  
Hedge cutter

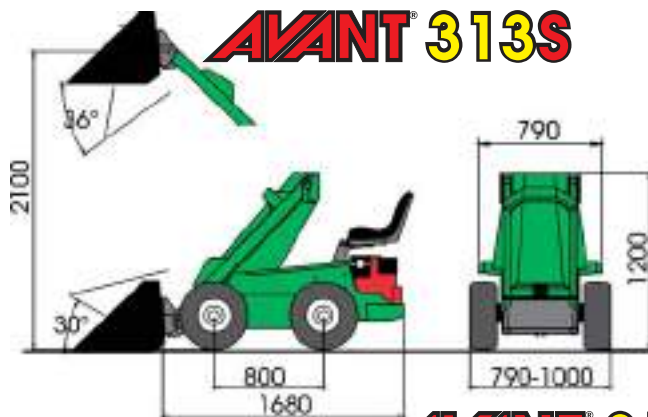

**AVANT 313S**

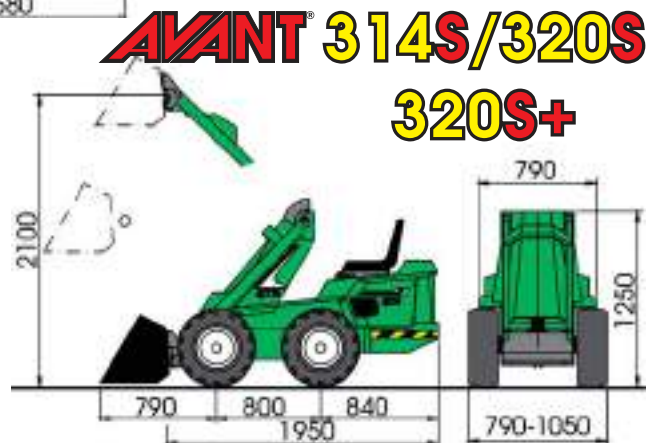

**AVANT 314S/320S**

**320S+**

More attachments available, please contact your local AVANT dealer.

**AVANT**<sup>®</sup>  
AVANT TECNO OY

[www.avanttecno.com](http://www.avanttecno.com)

e-mail: [sales@avanttecno.com](mailto:sales@avanttecno.com)

Ylötie 1  
FIN-33470 YLÖJÄRVI  
FINLAND  
Tel. +358 3 347 8800  
Fax +358 3 348 5511

AVANT has a policy of continuing improvement, and retains the right to change specifications without notice.