

SR-SERIES

SR-70/SR-80 ***Rubber Track Loaders***



Operation and Maintenance Manual



INTRODUCTION



Thank you for purchasing an ASV Rubber Track Loader. With this machine, you will be able to perform tasks faster and more efficiently than with any other machine its size.

The SR-70/80 are rugged and agile machines capable of working on a variety of challenging terrains. They are designed to be very safe, but safe operation also requires caution and attentiveness on the part of the operator.

There are many hazards that can be encountered during operation of an off highway utility vehicle such as the SR-70/80. With this in mind, it is the responsibility of each operator to read and fully understand this manual before attempting to operate the machine. Machine damage, bodily injury, or even death may result if the procedures and precautions described in this manual are not followed closely.

Machine Orientation

Terms like **front**, **rear**, **left**, and **right** are used throughout this manual to describe portions of the machine. They are to be understood from the perspective of an operator seated inside the cab.

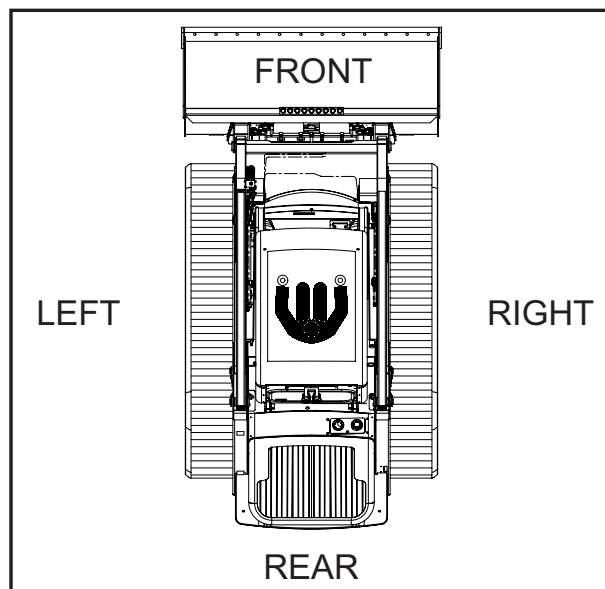



SAFETY SYMBOL

This symbol means: **Attention! Be alert!**
Your safety is involved!

A safety message will follow this symbol describing the hazard and the precautions that need to be taken to ensure your safety.

Read and understand all safety messages in order to protect yourself and others from personal injury or death.

These safety messages are identified by the words:
DANGER, WARNING, and CAUTION.

	DANGER
<p>“DANGER” refers to an imminently hazardous situation that may result in serious injury or even death.</p>	

	WARNING
<p>“WARNING” refers to a potentially hazardous situation that may result in serious injury or even death.</p>	

	CAUTION
<p>“CAUTION” refers to a potentially hazardous situation that may result in damage to the machine or its components.</p>	

The word “Note” is used throughout this manual to draw your attention to specific topics or to supplement the information provided in that section.

It is not possible to anticipate every potential hazard. The safety messages included in this document and displayed on the machine are not all-inclusive. They are intended to make you aware of potential risks and encourage a safe approach to operation, inspection and maintenance of the machine. Do not operate the machine until you are sure you have a thorough understanding of its operation, inspection and maintenance. It is your responsibility as the operator to exercise caution while performing these tasks to ensure your safety and the safety of others.

	WARNING
<p>Read and understand this manual prior to operating, inspecting, or attempting to maintain the Rubber Track Loader. Performing any of these tasks incorrectly can lead to machine damage, personal injury or even death.</p>	

MACHINE IDENTIFICATION

Serial Numbers

Product ID Number

The Machine PIN is located on the front of the cab near the lower right corner of the door opening. This number must be provided when contacting your dealer regarding parts, service, warranty or accessories.

Warranty claims will not be processed unless the machine PIN is provided.



Engine Serial Number

The Engine serial Number is located on a metal identification plate fastened to the engine valve cover at the rear of the machine.



Manual Storage

The manual storage compartment is located in the lower left portion of the cab near the operator's left leg.



TABLE OF CONTENTS

Introduction	1
Safety Overview	2
Machine Identification.....	3
Safety	6
Controls	14
Operation.....	22
Maintenance	32
Troubleshooting.....	58
Machine Specifications	63
Limited Warranty.....	64
Standard Torque Guidelines	65
Recommended Fluids	66
Service Log.....	67

Features 7

Tipping Load/Operating Cap./GVW 9

Fire Prevention..... 10

Warning Decals..... 11

SAFETY

Features

The SR 70/80 rubber track loaders are equipped with many safety features to reduce the possibility of injury to the operator during operation.

These features include:

A. Seat Belt

The seat belt is designed to keep the operator securely fastened in the seat should the machine encounter uneven terrain or come to a sudden stop during operation. It is equipped with a safety switch that is activated when the seat belt is clicked into position around a seated operator. This switch has been included to ensure that the seat belt is fastened before any motion is allowed to take place. Always fasten your seat belt prior to operating the machine. Serious injury or even death could result if your seat belt is left unfastened during operation.

B. Lap Bar Restraint

The lap bar restraint acts in conjunction with the seat belt to keep the operator securely fastened in the seat.

C. Operator Presence Seat Switch

This switch ensures that the operator is seated inside the machine before any motion is allowed to take place. This safety switch is activated when an operator is seated in the cab.

D. Auxiliary Hydraulic Safety Switches

These switches have been included to ensure that attachments do not engage when the machine is started. They must be locked into their neutral positions in order for the machine to start.

E. Parking Brake

The SR 70/80 are equipped with parking brake mechanisms. The brake effectively locks the transmission when activated to prevent machine movement.

Note: The lift arm control will still function normally when the parking brake is active.

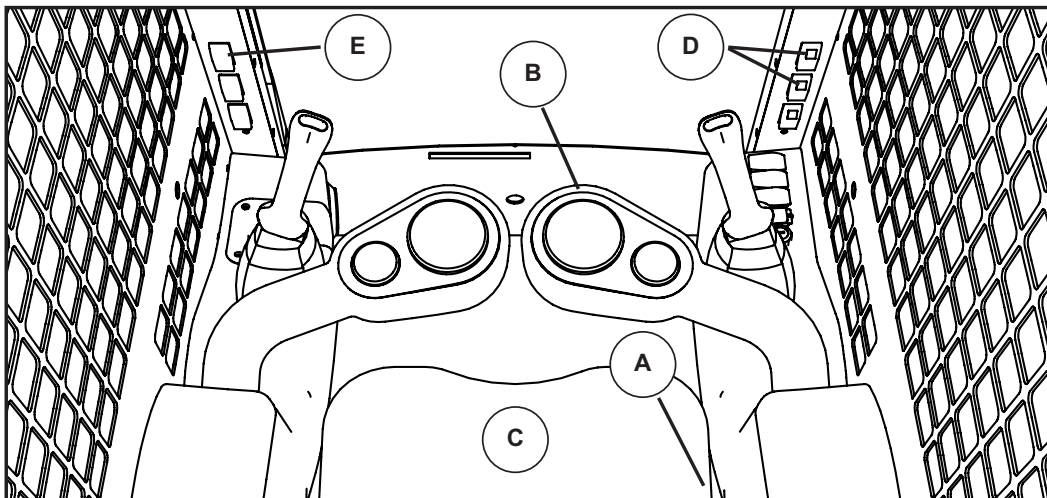

F. Power Quick-Attach Safety Switch (if equipped)

The purpose of this switch is to ensure attachments are properly fastened to the machine prior to operation. The engine will not start unless this switch is in the locked position. When installing an attachment, always perform a visual check to make sure it is correctly attached and locked in place prior to use.

Note: Items D and F are equipped with small orange locking devices. In order to move these switches, you must first disengage the locking devices by sliding them downward. The switches may then be moved into the desired positions.

G. Lift Arm Brace

Each machine is equipped with a brace to ensure your safety during service work or maintenance. Prior to performing any service or maintenance that requires the lift arms to be in the raised position, follow the lift arm brace installation procedure located on page 34.

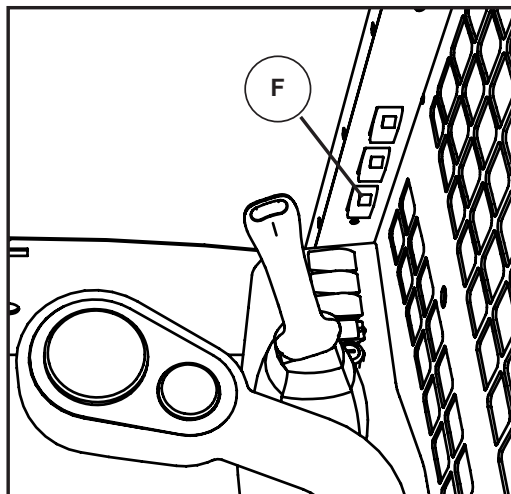

H. Escape Hatch

The rear window on the SR-70/80 serves as an escape hatch in an emergency situation. It is identified by a yellow triangular tag attached to the rubber molding surrounding the window. To exit through this opening, grab hold of the tag and pull to remove the molding. This will allow the window to be pushed out. Then carefully crawl out of the opening to safety.

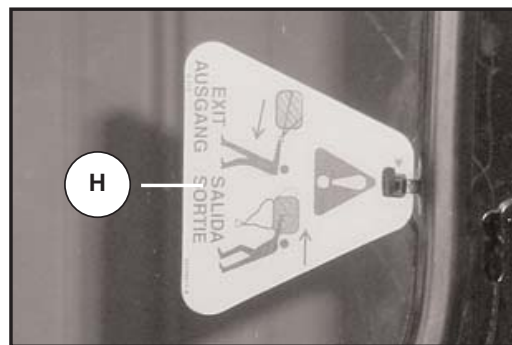
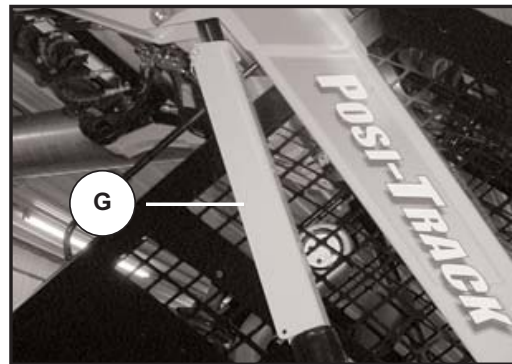

SAFETY

Tipping Load/Operating Capacity/GVW

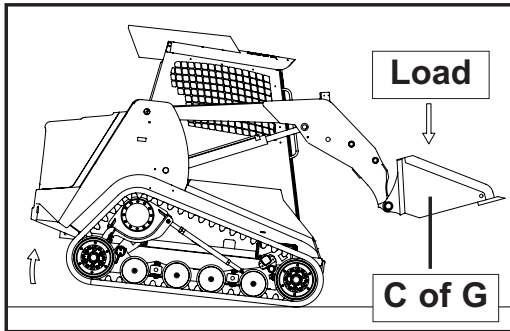

Tipping Load

The tipping load is the amount of weight that, when applied to the bucket center of gravity, causes the machine to begin tipping forward.

The tipping load is calculated with the machine still and on level ground, equipped with a standard dirt bucket that is raised to the point in the lift arm path where the load is positioned furthest from the machine.

Rated Operating Capacity

The rated operating capacity (ROC) is a percentage of the tipping load. The ROC is equal to 35% of the tipping load for traditional track loaders, or 50% of the tipping load for wheeled skid steer loaders. ASV publishes both the 35% and the 50% rating for reference and comparison.

The ROC applies only to the bucket attachment. Pallet forks or other attachments often move the center of gravity further away from the machine reducing the ROC.

Do not exceed the rated operating capacity for your machine.

Doing so could result in serious injury to the operator and or damage to the machine. The operating capacity ratings for the SR-70/80 are located on page 63.

Note: SAE J818 standards define operating capacity ratings for rubber tired skid steer loaders (50% tipping load) and tracked loaders (35% tipping load). There are no standards defining the operating capacity of machines equipped with suspended undercarriages or rubber tracks.

Gross Vehicle Weight

The G.V.W. of the SR-70 and 80 machines should never exceed 11,500Lbs. for the SR-70 and 12,500 lbs. for the SR-80 during operation. This weight excludes an operator, but does include any accessories, attachments or material being moved.

Operating the machine in excess of the the G.V.W. will void the warranty.

Fire Prevention

Rubber Track Loaders have components that operate at high temperatures. Steps must be taken to make sure that flammable items are kept clear of these components during operation. Failure to do so may result in a fire.

The main heat sources in the vehicle are the engine and the exhaust system. The electrical system could also be a source of heat/sparks if damaged or poorly maintained.

In some work environments, flammable items such as leaves, straw and brush cutting debris may come in contact with these sources. It is very important that these flammable items be removed often from areas close to hot components. If debris is allowed to accumulate, a fire may result posing a risk to the operator and the machine. A fire can cause machine damage, severe injury or even death.

Listed are a set of precautionary tasks that should be performed daily or more often if necessary. Repair or replace worn or damaged components as needed to ensure safe machine operation.

Precautionary Tasks:

- With the engine off and cool, remove any debris present in the engine compartment and chassis area (under cab). Remove the belly pans and pressure wash these areas to clean them properly.
- Check the battery, fuse box, electrical wiring and connection points for damage or looseness.
- Check fuel lines for leaks or damage. Never allow open flame near fuel or fuel system components.
- Check hydraulic lines, hoses and fittings for damage or leaking fluid. Never use bare hands to check for leaks. Pressurized fluid can penetrate skin and cause injury or even death.



WARNING

- **Do not use ether or any other aerosol type starting aid to start the engine.**
- **Always stop the engine and allow the machine to cool prior to adding fuel.**
- **Do not smoke or allow open flame near the machine while refueling.**

SAFETY

Warning Decals

There are decals positioned throughout the machine to warn operators of potential hazards. They must be observed and obeyed to avoid risks of machine damage, personal injury or even death. They are displayed here along with supplementary graphics that help to illustrate their intent and significance.

⚠ WARNING ⚠

Entering & Exiting
Maintain 3-point contact with step and hand rails.

Pre-Start Checklist

1. Operator seated in cab.
2. Seat belt fastened.
3. Lap bar pivoted down.
4. Joystick controls in neutral position.
5. Quick attach switch in locked position.
6. High & low flow auxiliary switches off.

Engine Warm-Up
Allow the engine to warm up prior to operation.

Carrying Loads
Carry loads low. Load, unload and turn on level ground.

Inclines
Travel with heaviest end of machine facing uphill.



Riders
Riders not permitted.

Work Platform
Never use a work tool as a work platform.

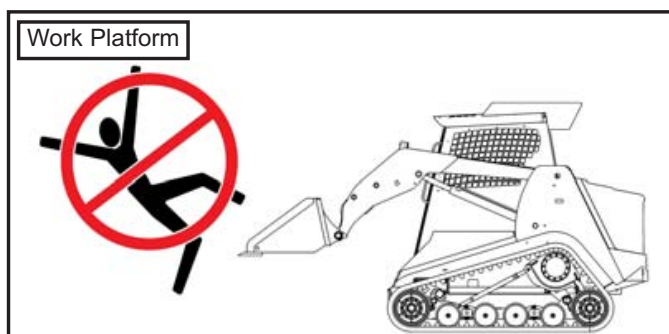
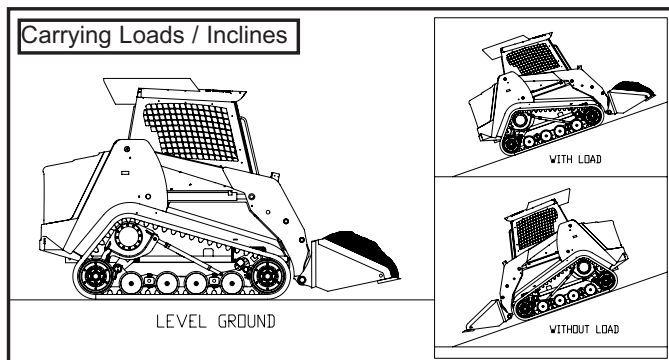
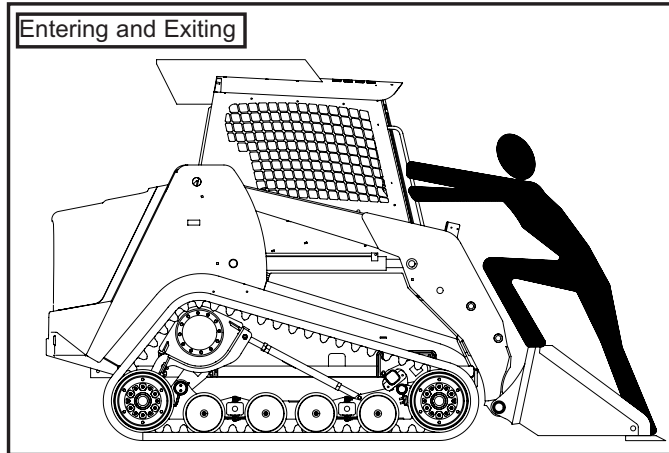
Disclaimer
Failure to observe and comply with the warnings listed above may result in machine damage, personal injury, or even death. 2045-469



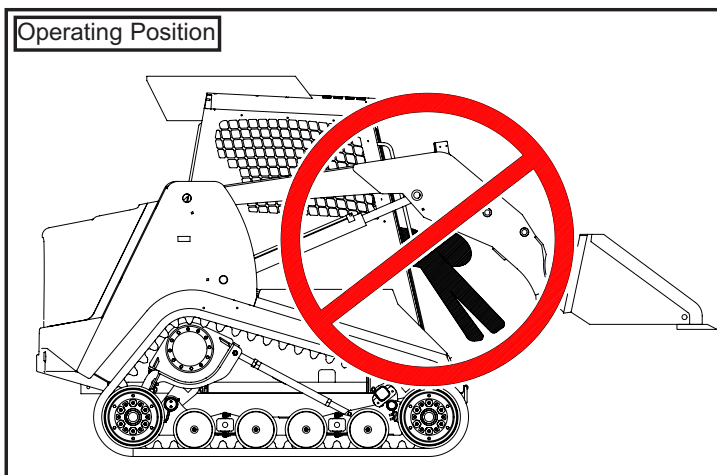

	WARNING	Keep away from tracks while machine is in motion. Serious personal injury or even death may result.
	CAUTION	Inspect undercarriages daily for accumulation of debris. Build-up of debris may shorten component life and decrease machine performance. 2045-467

 DANGER 
<p>Prior to Operating Read and fully understand the operation and maintenance manual prior to operating this machine.</p>
<p>Operating Position Never operate the machine with any part of your body protruding out of the operator enclosure.</p> <p>Failure to do so may result in serious injury or even death. 2045-472</p>

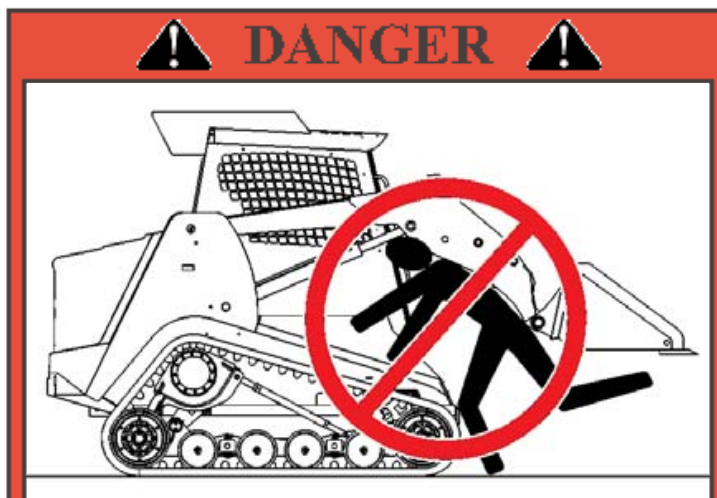

<p style="text-align: center;">2-Speed (if equipped)</p> <p>To engage: Press the button located on the front of the right joystick control.</p> <p>To disengage: Press the button a second time.</p>



 WARNING 
<p>Brushcutting Brushcutting, mowing or operations that generate airborne debris can cause fires.</p> <p>With the engine off and cool:</p> <ol style="list-style-type: none"> 1. Inspect the engine compartment and any other areas containing hot or rotating parts 2. Thoroughly clean these areas as often as necessary to avoid combustion. <p>Failure to do so could result in fire that may cause machine damage, personal injury, or even death. 2045-468</p>

<p style="text-align: center; font-weight: bold; font-size: 1.1em;">Keep out from under raised lift arms!</p> <p>Do not go beneath raised lift arms unless the lift arm brace has been properly installed. See operation and maintenance manual for installation procedure.</p> <p>Failure to observe or comply with warnings may result in serious injury or even death. 2045-466</p>

Instrument Display	15
Switch Panels.....	16
Drive & Lift Arm	17
Throttle/Electric Attachment.....	18
Auxiliary Hydraulic.....	19
Two Speed/Power Quick Attach.....	21

CONTROLS

Instrument Display

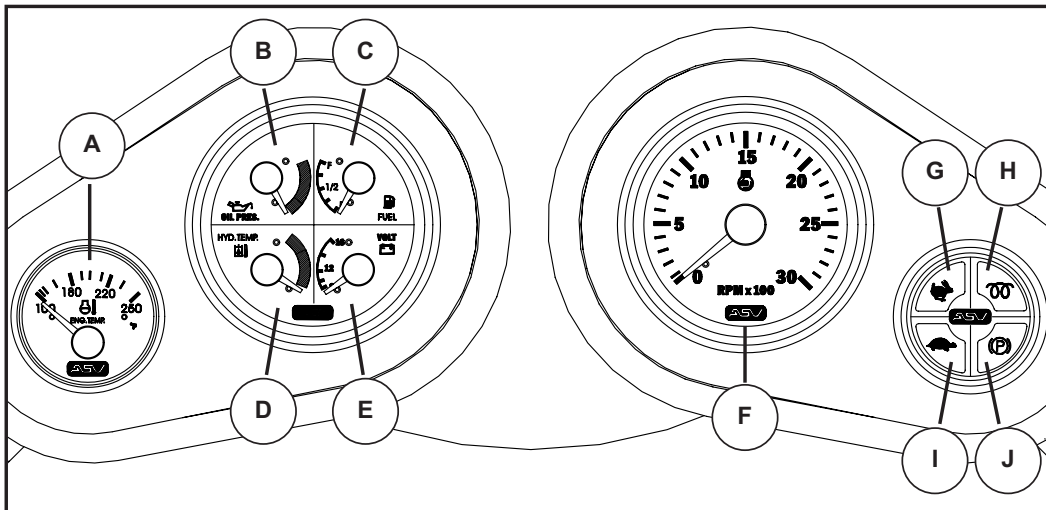

There are many instruments involved in the safe operation of your machine. Make sure to learn the location, and function of each of these items prior to operating your machine.

Instrument Display

The instrument display has been configured for visibility and ergonomic function.

The display includes:

- A. Engine Temperature Gauge
- B. Oil Pressure Gauge
- C. Fuel Gauge
- D. Hydraulic Oil Temp. Gauge
- E. Voltmeter
- F. Tachometer
- G. High Range Indicator
- H. Glow Plug Operation Indicator
- I. Low Range Indicator
- J. Parking Brake Indicator
- K. Hour Meter

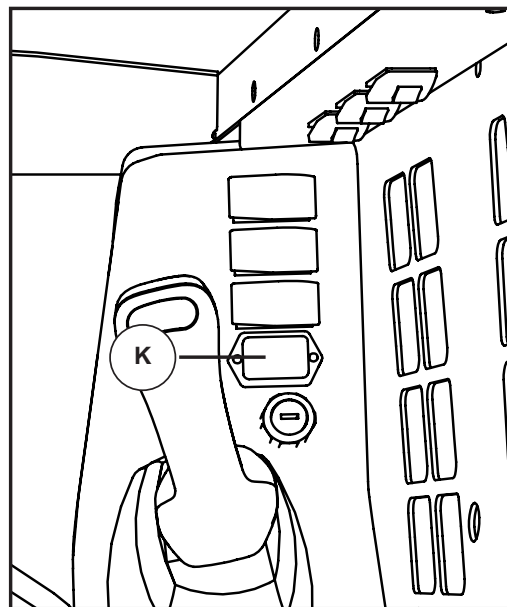

The glow plug operation light should illuminate only when the ignition switch is turned to the pre-heat position.

Pay close attention to the display during operation to ensure that all systems are functioning properly.

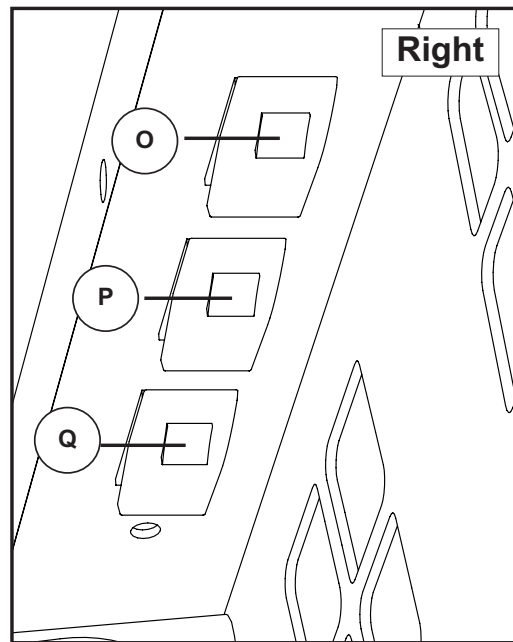
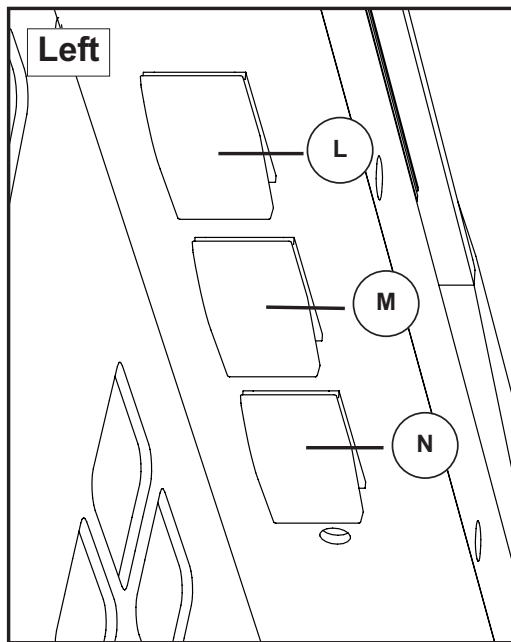

Switch Panels

There are three main panels which house the switches used to control various functions throughout the machine.

The switch panels include:

- L.** Parking Brake Switch
- M.** Headlight Switch
- N.** Bucket Positioning Switch
- O.** High Flow Aux. Switch
- P.** Low Flow Aux. Switch
- Q.** Hyd. Quick Attach Switch*
- R.** Heater Fan Switch**
- S.** Windshield Wiper Switch**
- T.** Beacon Switch**
- U.** Ignition Switch

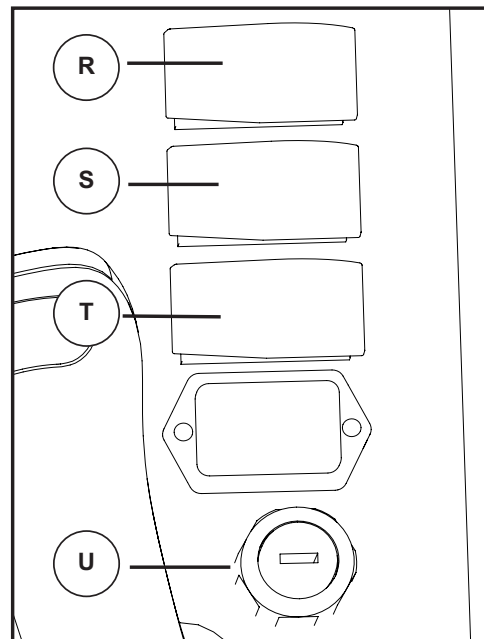

* Optional on SR 70

** Optional on SR 70/80

CONTROLS

Drive & Lift Arm

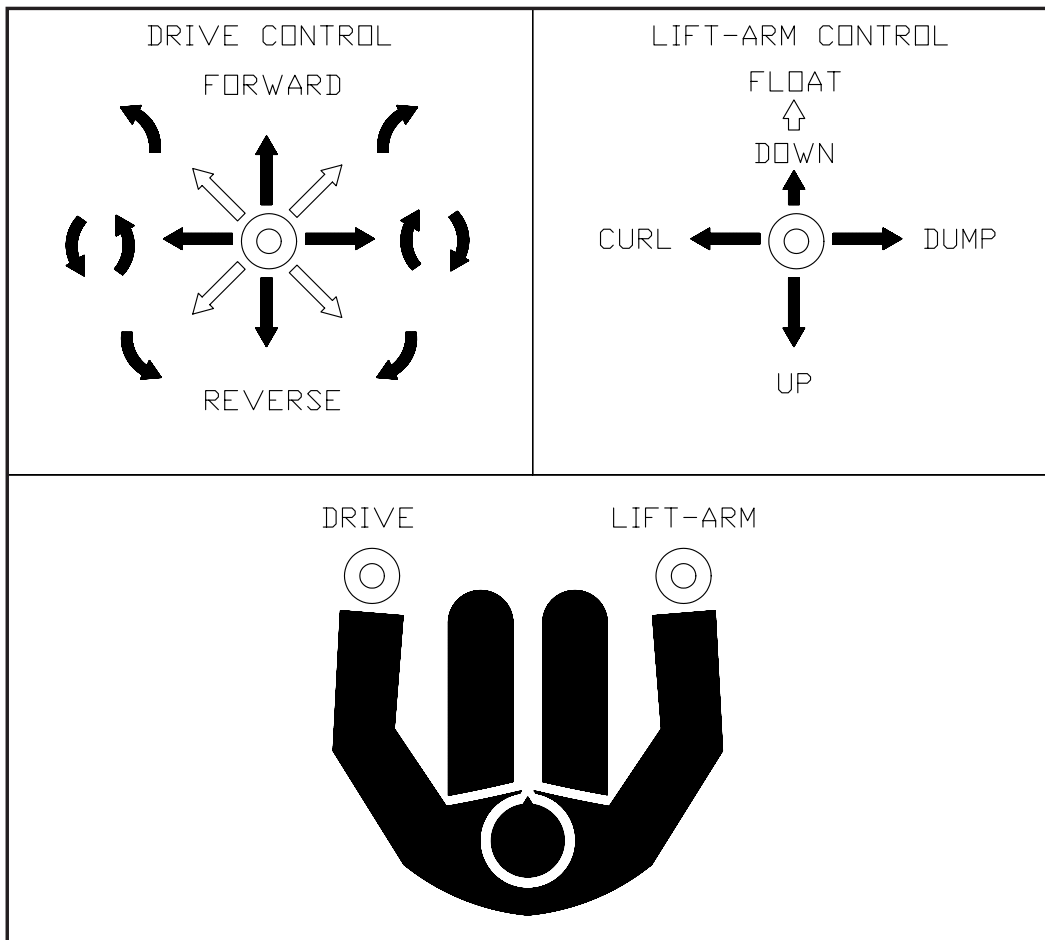

Drive Control

The SR-70/80 are equipped with pilot operated joystick controls. The drive control (left joystick) is used to control track motion. The illustration above shows the relationship between joystick and machine movement.

Note: The machine will not move as long as the drive control is in the neutral position. Each joystick is equipped with a spring return feature that automatically returns it to neutral position when released.

To stop a moving machine, release the left joystick altogether. This will stop the machine.

Lift Arm Control

The lift arm control (right joystick) is used to control the lift arms and attachment (bucket) movement. The illustration above shows the relationship between joystick and lift arm/attachment movement.

The SR-70/80 are equipped with a float function that allows the lift arms and attachment (bucket) to follow the contours of the ground as you move with only their own weight acting as downforce.

- **To engage:** push the joystick fully forward into position. (see illustration)
- **To disengage:** pull back quickly on the joystick.

Throttle/Electric Attachment**Throttle Controls**

The throttle controls engine RPM. When performing work that requires delicate, precise movements, use a lower RPM. When more speed, horsepower, or flow is required, use a higher RPM.

The SR 70/80 are equipped with foot operated throttle mechanisms.

- To increase engine RPM, press the front (toe) of the foot pedal slowly towards the floor until the desired rpm has been reached.
- To decrease RPM, press the rear (heel) of the pedal towards the floor.

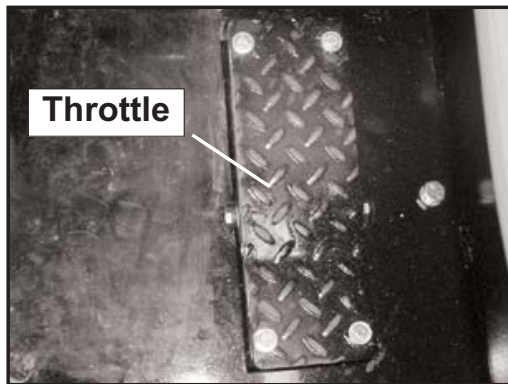
**Electric Attachment Control**

Most attachments for ASV Rubber Track Loaders are controlled hydraulically, but some require electrical input as well. When electrical input is required, the four buttons on the drive control (left) joystick can be utilized to send electrical current to the receptacle located on the upper left side of the lift arms.

Note: ASV receptacle style and pin designation may differ from those utilized by other manufacturers. To ensure proper function, use only ASV approved attachments.

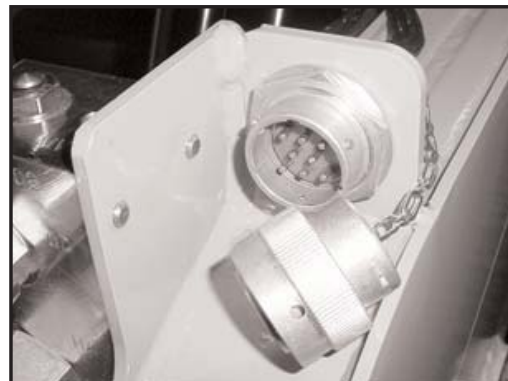
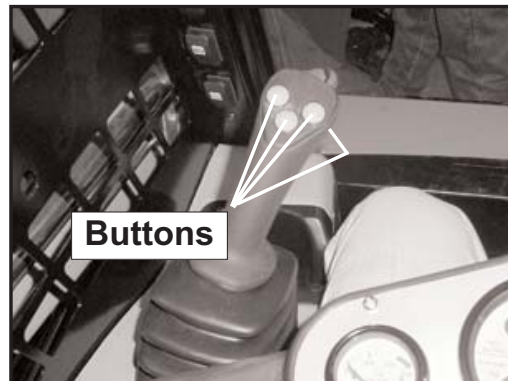

CONTROLS

Auxiliary Hydraulic

The SR70/80 are equipped with high and low flow auxiliary hydraulic circuits that allow for the use of hydraulic attachments.

The couplers for the auxiliary circuits are located on the left side of the lift arms near the front of the machine. They are positioned from top to bottom as such: (see photo)

- A. Case drain
- B. High flow
- C. High flow
- D. Low flow
- E. Low flow

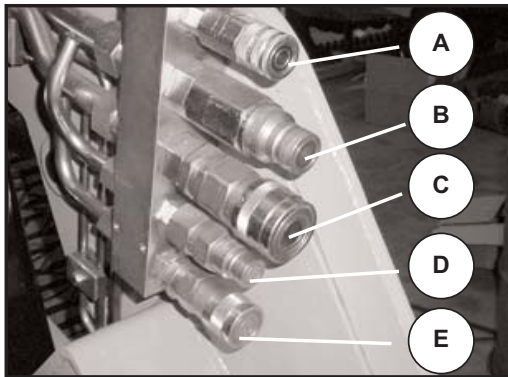

The SR-70/80 uses a variable displacement pump to supply oil to the low and high flow auxiliary circuits. This pump displaces 30gpm when the high flow switch is activated and 20gpm when the low flow switch is activated.

To prevent an operator from accidentally sending 30gpm through a low flow attachment, the machines are equipped with a switch mechanism that disables the high flow switch when an attachment is connected to the low flow quick couplers.

Note: Low and high flow circuits may not be used simultaneously.

Low Flow Intermittent

The low flow auxiliary circuit can be utilized intermittently or continuously. It also has the capability of varying attachment speed through the use of a spring centered roller switch (F) located on the back of the right joystick.



Attachment direction is determined by rolling the switch to the right or left or center. Attachment speed is determined by the amount that it is rolled in the chosen direction. This variability gives the operator more control over the actuation speed of the attachment.

To activate the low flow auxiliary hydraulic circuit intermittently, roll the switch left or right of center.

- To pressurize the upper low flow quick coupler, roll the switch to the left of center.
- To pressurize the lower low flow quick coupler, roll the switch to the right of center.
- To de-activate low flow intermittent operation, release the variable switch and flow will cease.

Auxiliary Hydraulic**Low Flow Continuous**

To activate the low flow auxiliary hydraulic circuit continuously, depress the rocker type switch located on the switch panel. (H)

- To pressurize the upper low flow quick coupler, press the top of the switch.
- To pressurize the lower low flow quick coupler, press the bottom of the switch.
- To de-activate low flow continuous operation, move the switch into the middle (neutral) position.

High flow

To activate the high flow auxiliary hydraulic circuit, depress the rocker type switch located on the switch panel. (G)

- To pressurize the upper high flow quick coupler, press the top of the switch.
- To pressurize the lower high flow quick coupler, press the bottom of the switch.
- To de-activate high flow continuous operation, move the switch into the middle (neutral) position.

Note: When connected to an attachment, the auxiliary switches have the effect of reversing flow through their respective circuits when switched or rolled from one position to the other.

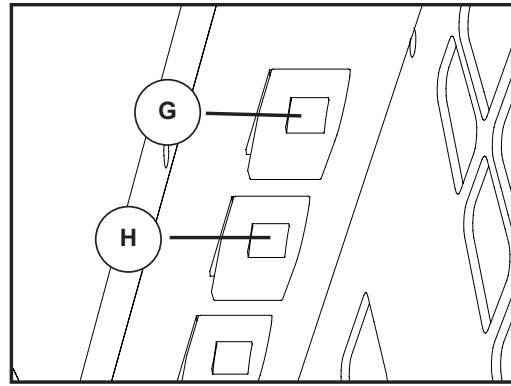

Note: The high and low flow auxiliary hydraulic switches are equipped with locking devices. Their purpose is to lock the switches into neutral position when not in operation. These locking devices must be disengaged prior to use. To disengage, slide the locking device downward. The switch can then be moved into position.

**CAUTION**

It is very important to match G.P.M. ratings when utilizing attachments. If you use an attachment that is rated for more G.P.M. than is available in an auxiliary circuit, attachment performance will suffer. If you use an attachment that is rated for less G.P.M. than is available in an auxiliary circuit, you will overheat your hydraulic system and most likely damage your machine/attachment. ASV recommends using only attachments that are designed to work with your specific machine.

CONTROLS

Two Speed/Power Quick Attach

Two Speed

The SR 80 is equipped with a two speed drive system with low and high range.

- **Low range** is best suited to performing strenuous tasks or running attachments.
- **High range** is intended primarily for transporting.

To activate high range, press the button on the front of the right joystick. To return to low range, press the button a second time.

There is a high/low range indicator light located in the instrument display to confirm which range you are operating in.

Note: When shifting between ranges, slow the machine down to ensure a smooth transition.

Power Quick Attach

The SR machines are available with a power quick attach feature that allows the operator to fasten and unfasten attachments without exiting the machine. (SR-80-standard/SR-70-optional)

- To lock the power quick attach, depress the rocker type switch located on the switch panel into the lock position.
- To unlock the quick attach, move the switch to the unlock position.

Note: The power quick attach switch is equipped with a locking device. The device must be disengaged in order to unlock the quick attach. To disengage, slide the locking device downward. The switch can then be moved into the unlocked position.

Pre-Operation	23
Starting Procedure	24
Operation Techniques	25
Attachments	29

OPERATION

Pre-Operation

Pre-Operation Safety Check

Before operating the machine, perform a pre-operation safety check. Inspect the machine for any items that may affect safe operation.

Check to make sure:

1. Engine compartment, chassis and coolers are clean and free of debris. (see page 39)
2. Windows and lights are clean and unobstructed.
3. Tracks are in good working condition.
4. Track tension is adjusted correctly.
5. All fluids are filled to appropriate levels.
6. Battery cables are in good condition and securely fastened.
7. Accessory belts are in good condition and properly tensioned.
8. Hydraulic hoses and fittings are in good condition. (No visible wear or leaks)
9. Joysticks and high/low flow auxiliary switches are in their neutral positions.
10. Power quick attach is in locked position. (if equipped, visually verify)
11. Hood is closed and bystanders are clear of any moving parts.
12. All grease points have been lubricated.

Note: The parking brake is automatically activated when the operator removes the seat belt or leaves the operator seat.

Note: The parking brake should be manually activated when using an attachment that requires the machine to remain stationary during operation.



	WARNING
<p>Entering or exiting the machine under raised lift arms can cause serious injury or even death. Never allow anyone to go beneath unsecured lift arms.</p>	

Starting Procedure

Upon completion of the pre-operation safety check, if all items are in compliance, you are ready to start your machine.

To start the machine:

1. Enter the machine (lift arms in lowered position) from the front while maintaining at least 3-point contact with the machine at all times to ensure your safety. (2-hands, one foot or vice-versa)
2. Sit down into the operator seat, fasten the seat belt securely around your lower abdomen and pivot the lap bar restraint into position.
3. From the SLOW position, move the throttle to 1/3 open by pressing the foot pedal forward approximately 1/3 of its travel.
4. Insert the key into the ignition switch and turn it to the left for approximately 6 seconds to pre-heat the engine. During this time, the glow plug operation light will illuminate.
5. Once the engine has been pre-heated, turn the key to the right and hold to start the engine. Release the key as soon as the engine fires.

6. Once running, reduce throttle to a low idle by pushing back slowly on the foot pedal with your heel. Allow the engine to idle for 3-5 minutes to reach operating temperature.
7. Once the engine has reached operating temperature, set desired RPM by moving the foot pedal into position.

The machine is now ready for operation.



WARNING

Failure to fasten your seat belt could result in serious injury or death.



WARNING

Do not use aerosol type starting aids such as ether. Explosion may result.



CAUTION

Do not crank the engine for more than 20 seconds. Allow the starter to cool for two minutes before cranking again.

Operation Techniques

Operating Your Machine

Operating an ASV Rubber Track Loader is intended to be as safe and simple as possible. The controls section of this manual covers the various controls used to operate the machine. Each operator should take the time necessary to familiarize him/herself with the controls section prior to attempting to operate the machine.

This section covers safe operation procedures and some basic do's and don'ts to keep in mind while operating the machine. In order to learn to properly operate the machine, it is very important that each operator read and understand this manual thoroughly. It is also very important to take the time necessary to become skilled in operation techniques in accordance with the instructions in this section. Do this in an open area that is free of potential hazards and bystanders. This will give the operator space to practice without worry of injuring people or damaging property including him/herself and the machine.

Dirt Work

ASV Rubber Track Loaders provide far superior traction and floatation than traditional wheeled loaders. This added capability enables an operator to fill the bucket by slowly driving into a pile of dirt without having to depend on vehicle momentum to plunge into the pile.

Machine weight is more evenly distributed throughout the chassis with this design providing significantly more down pressure at the front of the machine than traditional wheeled loaders. The result is improved cutting and back dragging performance without the need to force the front of the machine off of the ground.



CAUTION

Pushing the front of the machine off of the ground with the bucket or attachment will reduce traction and machine component life.

The lift arms are meant to rest against the frame while digging or grading. Utilizing your machine in this manner will minimize stress on components and maximize machine performance and efficiency.

Filling The Bucket

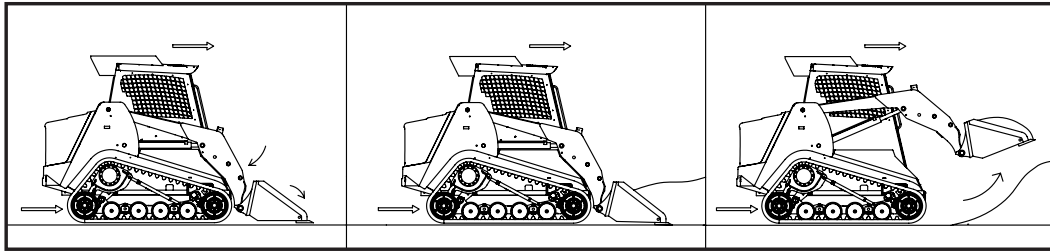

Steps: (see illustration)

1. Lower the lift arms until they rest on the frame.
2. Tilt the bucket slowly forward until the cutting edge engages the ground.
3. Drive the machine forward until the bucket is full of material.
4. Curl the bucket and raise the lift arms simultaneously to break the load free from the pile.
5. Maneuver the machine clear of the pile and then lower the lift arms, keeping the bucket curled upward, to approximately 10-12" above the ground for transporting.

Grading

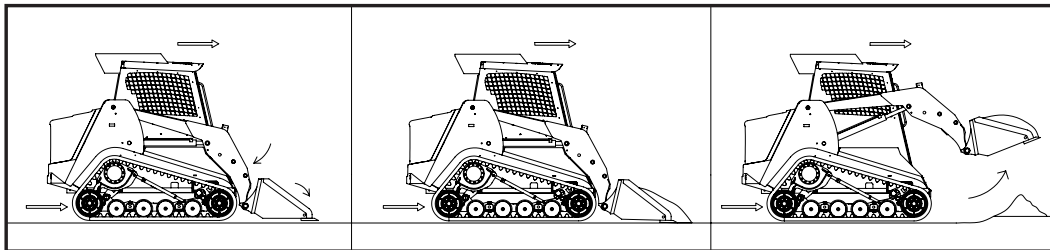

Steps: (see illustration)

1. Lower the lift arms until they rest on the frame.
2. Tilt the bucket slowly forward until the cutting edge engages the ground.
3. Drive the machine forward making slight bucket angle adjustments to vary cut depth as necessary.
4. When full, curl the bucket and raise the lift arms simultaneously. Once clear, lower them to approximately 10-12" above the ground for transporting.

	CAUTION
Do not push or pull dirt as done in digging, grading, or leveling operations with the bucket tilted fully forward into the "Dump" position. This will stress the bucket cylinders and may damage them.	

OPERATION

Operation Techniques

Leveling

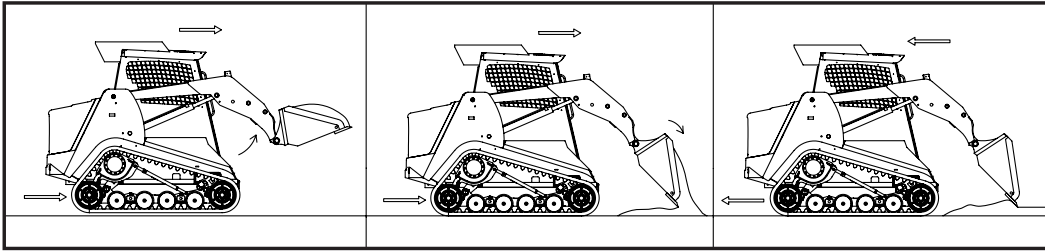

Steps: (see illustration)

1. Moving forward, raise the lift arms as you tilt the bucket slowly forward to evenly spread the material out over the ground.
2. Once the load is released, tilt the bucket forward to an angle 45° or less to the ground.
3. Lower the lift arms until the cutting edge rests on the ground.
4. Engage the float function and back the machine over the material varying bucket angle slightly as necessary to maintain grade.

Loading

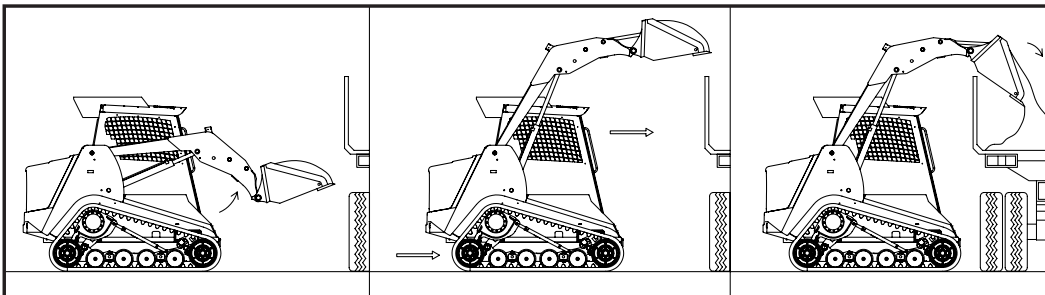

Steps: (see illustration)

1. Engage the self level (bucket positioning) function, then raise the lift arms upward until the bottom of the bucket clears the side of the truck bed or trailer.
2. Once clear, drive the machine forward until the pivot point of the bucket clears the bed side.
3. Tilt the bucket forward until all of the material has been released into the bed.

Note: It may be necessary to quickly tilt and curl the bucket while releasing material into the truck bed to evenly distribute the material within the bed.

Hill Side Operation

By design, Rubber Track Loaders are very stable on inclines. Machine weight is distributed evenly throughout the chassis and the suspended undercarriage track system provides excellent traction and floatation on nearly all surfaces.

Even with these capabilities, caution should always be exercised while operating the machine on an incline. Never operate the SR-80 on an incline in excess of 18° or an SR-70 on an incline in excess of 15°. Do not make sudden changes in direction, move slowly, and always carry loads low to maximize machine stability.

When turning on an incline, back down the hill while slowly turning until the machine is pointed in the desired direction. Then proceed forward.

Operation On Turf

One of the many features of a Rubber Track Loader is the ability to work on turf and similar finished surfaces with minimal surface disturbance.

The suspended undercarriage and track assemblies distribute machine weight extremely well. However, care should still be taken while operating on these surfaces to prevent blemishes.

Turning poses the greatest risk of surface disturbance during operation. Moving in a straight line across turf will cause little or no disturbance, whereas counter rotation will most likely cause blemishes.

While working on turf, make gradual turns. (see item D) If space is limited, turn gradually by moving back and forth until facing the desired direction. (see item C)

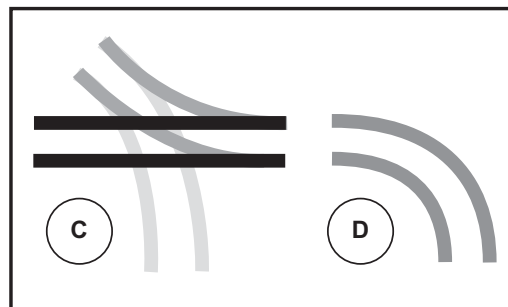

OPERATION

Attachments SR 70

Fastening

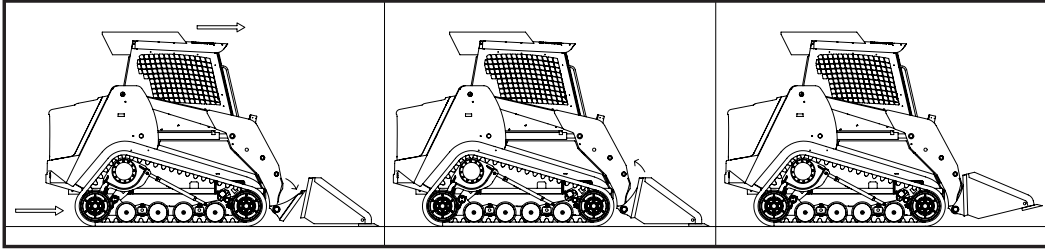

To fasten an attachment:

1. Make sure the locking levers are in their respective unlocked positions.
2. Drive the machine to the attachment and hook the top edge of the quick attach under the upper lip of the attachment.
3. Curl the quick attach slowly upward by moving the lift arm control joystick to the left until the attachment is properly mated with the quick attach mechanism. (Curl enough to lift the attachment off of the ground.)
4. Once the attachment is properly mated, move the two locking levers inward and downward to lock the attachment in place.

Note: When fastening an attachment, always visually verify that the attachment is locked in place prior to operation.

To unfasten an attachment:

1. Lower the lift arms so that the attachment is just barely off of the ground.
2. Pull the locking levers upwards and toward the outside of the machine to unlock the attachment.
3. Lay the attachment gently onto the ground by moving the lift arm control joystick slowly to the right.
4. Once the attachment is in contact with the ground, move the lift arm control joystick gently to the right until the quick-attach is clear of the attachment.
5. Back the machine away from the attachment.

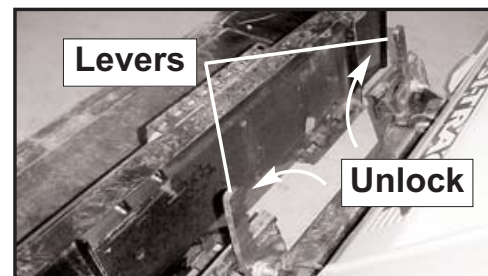

Unfastening

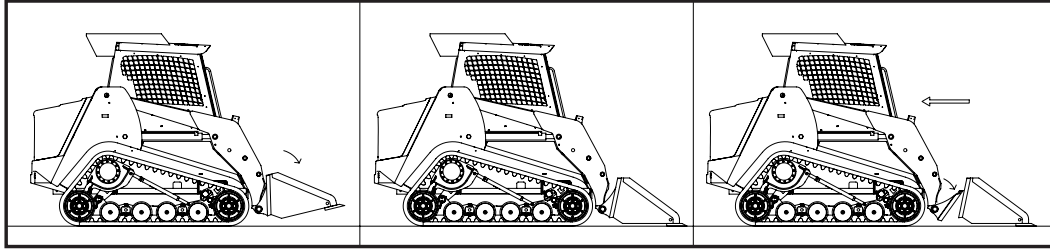

To fasten an attachment:

1. Move the power quick-attach switch into the “unlock” position.
2. Drive the machine to the attachment and hook the top edge of the quick attach under the upper lip of the attachment.
3. Curl the quick-attach slowly upward by moving the lift arm control joystick to the left until the attachment is properly mated with the quick attach mechanism. (Curl enough to lift the attachment off of the ground.)
4. Once the attachment is properly mated, move the power quick attach rocker switch located on the switch panel to the “lock” position. This will activate the locking cylinders and lock the attachment securely to the quick attach mechanism.

Note: When fastening an attachment, always visually verify that the attachment is locked in place prior to operation.

To unfasten an attachment:

1. Lower the lift arms so that the attachment is just barely off of the ground.
2. Move the power quick attach switch to the “unlock” position.
3. Lay the attachment gently onto the ground by moving the lift arm control joystick slowly to the right.
4. Once the attachment is in contact with the ground, move the lift arm control joystick gently to the right until the quick-attach is clear of the attachment.
5. Back the machine away from the attachment



Precautions/Safety Warnings	33
Lift Arm Brace Installation	34
Tilt-Up R.O.P.S./F.O.P.S. Cab	35
Jacking Procedure	36
Maintenance Schedule	37
Grease Points	38
Radiator-Oil Cooler/Engine Cleaning	39
Air Cleaner	40
Fuel Filter/Water Separator.....	42
Accessory Belts	43
Engine	45
Hydraulic System.....	48
Electrical/Undercarriages.....	50
Drive Sprocket Rollers	56

MAINTENANCE

Precautions/Safety Warnings

Precautions

Rubber Track Loaders require periodic maintenance to ensure proper performance and prevent costly down time. When service is required, ASV recommends that all work be done by an authorized ASV Dealer.

If you perform maintenance on your own machine, you should familiarize yourself with the information provided in this section on general maintenance. Incorrect or incomplete maintenance may cause improper or unsafe vehicle operation.

Problems caused by incomplete or improper maintenance are not eligible for warranty coverage.

Safety Warnings

Exercise caution when performing service work on the machine. Serious injury may result if the following guidelines are not followed.

- Always select a safe area to perform maintenance.
- Always select the proper tools for the work to be performed.
- Never work on a machine supported only by a jack. Always use ASV approved jack stands to support vehicle weight while performing service work.
- Never work under raised lift arms unless supported by an ASV approved lift arm brace.
- Always remove attachments prior to working underneath a machine.
- Never run the engine in a poorly ventilated area. Exhaust fumes are fatal when inhaled in sufficient quantities.
- Never smoke or allow open flame near flammable liquids or the battery. Fire or explosion may result.
- Always allow the engine to cool before performing maintenance work. Engine parts become very hot during operation and may cause burns if not allowed to cool sufficiently.
- Do not spill flammable liquids on hot engine parts. Fire may result.
- Do not perform maintenance on a machine with the engine running unless instructed to do so by your ASV service manual. Moving engine parts pose a safety risk and can cause injury or death if proper precautions are not taken.

Lift Arm Brace Installation

Lift Arm Brace Installation

The lift arm brace (A) is intended to keep service personnel safe when it is necessary to work on a machine with the lift arms in the raised position. It is not safe to rely on the hydraulic system to hold the lift arms in the raised position just as it is not safe to crawl under a machine supported only by a jack. The lift arm brace is used to support the weight of the lift arms much like jack stands are used to mechanically support vehicle weight.



WARNING

Do not work on or near the machine with the lift arms in the raised position unless the lift arm brace has been correctly installed.

To install the lift arm brace:

1. Park the machine on level ground in a safe area for performing service work.
2. Remove any attachments that may be fastened to the quick attach.
3. Have an assistant remove the retaining pins (B) securing the lift arm brace and remove it from the machine.
4. Make sure bystanders are clear of the lift arms, then raise them to the upper limit.
5. Have an assistant install the brace around the cylinder shaft as shown and reinstall the pins to secure it to the cylinder.

6. Lower the lift arms slowly until they come to rest on the brace.
7. It is now safe to shut the engine off and exit the machine.

To remove the lift arm brace:

1. Start the machine and raise the lift arms until they are clear of the brace.
2. Once clear, have an assistant remove the brace from the cylinder and stow it on the machine with the pins.
3. Once the brace has been stowed and the assistant is clear of the lift arms, lower the arms to the ground and shut the engine off to complete the procedure.

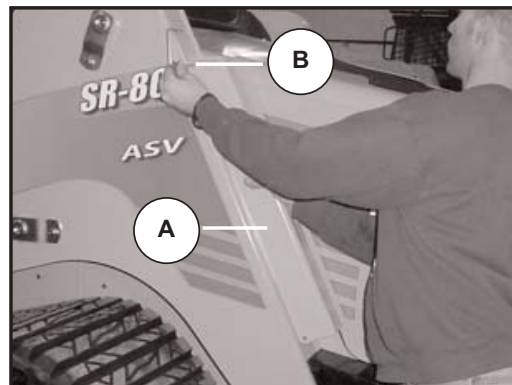

MAINTENANCE

Tilt Up R.O.P.S./F.O.P.S. Cab

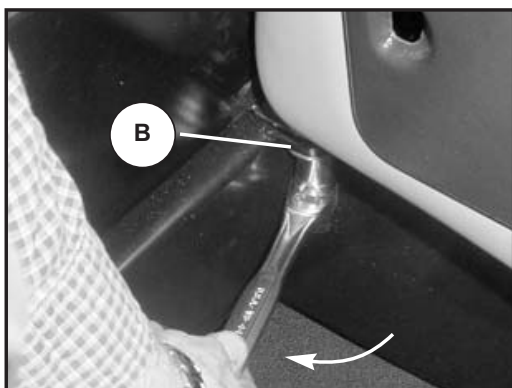

Tilt-Up Cab

The ROPS/FOPS approved cab (A) tilts up to allow easy access to components while performing maintenance. It is equipped with a gas spring assist and a brace mechanism to hold it in place while tilted.

To tilt the cab:

1. Remove any attachments that may be fastened to the machine.
2. (Optional) Raise the lift arms and secure them with the lift arm brace. (See page 34.)
3. Remove the two bolts (B) that fasten the cab to the footwell. They are located inside the cab, one in each of the lower front corners.
4. Once the bolts have been removed, tilt the cab slowly upwards. The cab brace (C) should fall onto the shoulder bolt (D) locking the cab in its upright position.

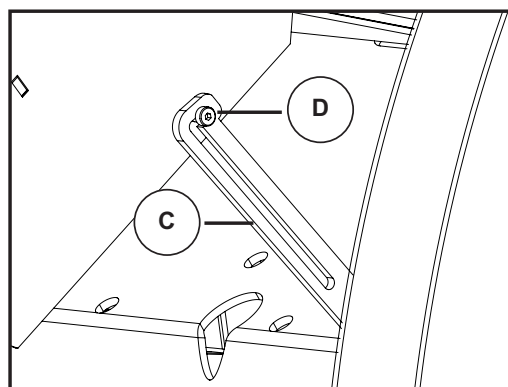

To lower the cab:

1. Raise the cab brace so that the locking channel is clear of the shoulder bolt.
2. Hold the brace upwards and lower the cab until the locking channel is clear of the shoulder bolt then release the brace.
3. The cab is now free to be lowered into operating position.
4. Lower the cab completely and then fasten it to the footwell with the two bolts removed previously.

The cab is now secure.

Jacking Procedure

Occasionally, your machine may need to be suspended off of the ground to perform maintenance. Exercise caution when jacking the machine. Always use a jack that is capable of lifting the machine and support its weight with ASV approved jack stands while suspended. Never work on or under a machine supported only by a jack.

To safely jack your machine:

1. Remove any attachments that may be fastened to the machine and raise the lift arms.
2. Install the lift arm brace as instructed on page 34.
3. Once the lift arms are secured, carefully exit the machine.
4. Roll or slide your jack under the front of the machine and center the lifting pad directly under the middle of the front torsion axle.
5. Once in place, jack the machine upward making sure it remains stable until it has reached sufficient height to install an ASV jack stand beneath the machine. (fig. 1)

6. Slide the jack stand into place making sure it is centered under the machine (left to right when viewed from the front) and far enough back for the machine to remain stable when the jack is lowered and the front of the machine rests on the stand. (fig. 2)
7. Once the stand is in place, slowly lower the machine onto the stand and then remove the jack.

Repeat steps 4-7 at the rear of the machine should both ends of the machine need to be off of the ground for service.



 **CAUTION**

Lift the machine under the torsion axles only! Jacking the machine in any other place may cause damage.

MAINTENANCE

Maintenance Schedule

<u>Maintenance Item</u>	<u>Service required</u>	<u>Interval</u>	<u>Notes</u>	<u>Service Capacity</u>
Grease fittings	Lubricate	Daily	Grease often.	
Fluid levels	Check	Daily	Adjust levels as necessary.	
Fan-A/C belt tension	Check	Daily	Adjust tension as necessary.	
Fan-A/C belt condition	Inspect	Daily	Replace as a pair if worn or damaged.	
Water separator	Drain	Daily		
Track condition	Inspect	Daily	Replace if severely damaged.	
Track tension	Inspect	Daily	Adjust tension as necessary.	
Air cleaners	Inspect	Daily	Replace if damaged or heavily soiled.	
Radiator/oil cooler	Inspect	Daily	Clean often (as necessary).	
Undercarriages	Inspect	Daily	Clean often (as necessary).	
Engine compartment	Inspect	Daily	Clean often (as necessary).	
Drive sprocket rollers	Inspect	50 hr.	Replace if damaged or worn. (35% min.)	
Engine oil and filter	Replace	12 Mo. or 500 hr.	Harsh conditions (6 Mo./250 hr. interval)	9 qt.
Hydraulic filters (2)	Replace	250 hr.	Replace filters as a pair.	
Hydraulic oil	Replace	500 hr.	Service refill capacity only. (Dry: 21 gallons)	12.25 gal.
Water separator-fuel filter	Replace	500 hr.	Replace fuel filter element.	
Radiator coolant	Replace	3000 hr.	Coolant with SCA additive required.	3.125 gal
Case drain filter	None required	N/A	Replace if attachment drive motor fails.	

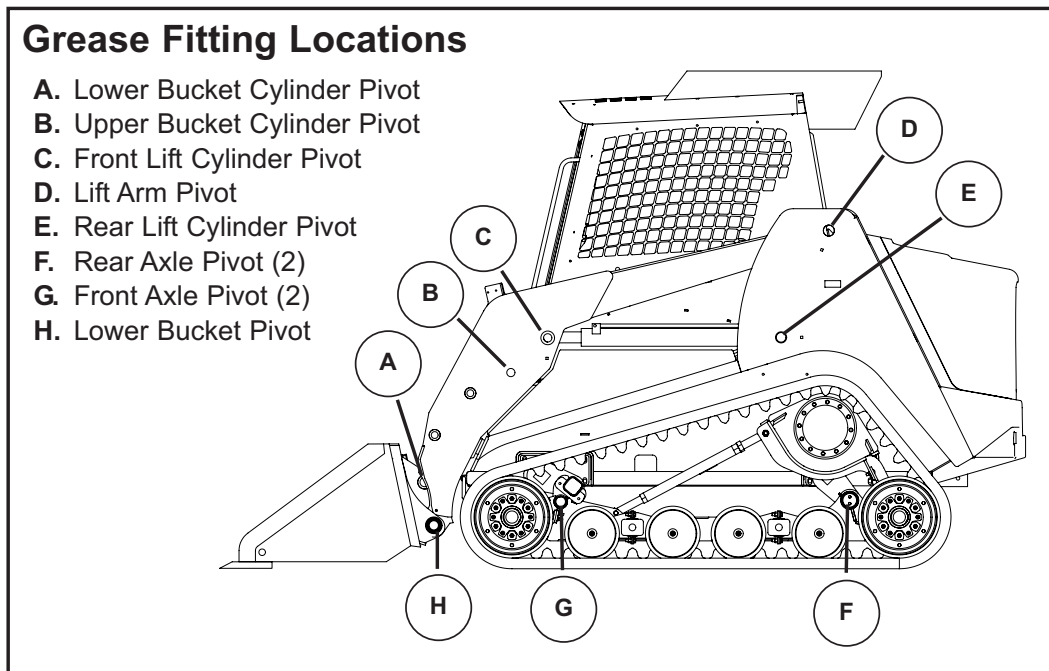

Grease Points

The SR 70/80 are equipped with grease fittings at pivot points throughout the machine. The illustration above shows the locations of all fittings on the left side of the machine. An identical fitting exists on the right side of the machine for each one identified in the illustration. Lubricate all fittings **DAILY** or after every 10 hours of operation to maximize component life and ensure proper machine function.

Radiator/Oil Cooler & Engine Cleaning

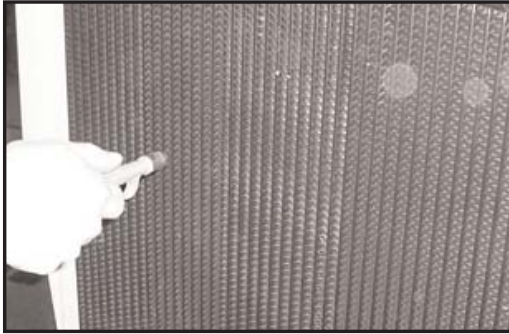

Radiator/Oil Cooler

The Radiator and Oil Cooler must be kept clean to ensure proper operation. Engine and hydraulic system overheating, damage and even failure can result if the radiator/oil cooler is not kept clean. A pressure washer or compressed air nozzle work well to blow debris clear of the fins in the oil cooler and radiator.

Note: If hydraulic oil or engine coolant temperature gauges indicate abnormally high temperatures during operation, increase cleaning intervals.

Note: In brush cutting applications check and clean the coolers often to avoid overheating.

To clean radiator/oil cooler:

1. Make sure the engine is **off, and cool.**
2. Using compressed air or a pressure washer, thoroughly clean radiator/oil cooler as shown.



Note: Make sure water nozzle is at least 12" (8" for air) from the cooler and that the spray is directed straight through the cooler or the cooling fins may be damaged (bent over) which will decrease cooling performance.

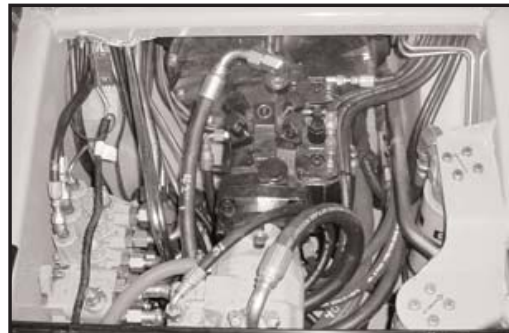

Engine

Periodic cleaning of the chassis area beneath the cab and engine compartment are also necessary to maintain safe operation. Clean as required.

1. Remove the belly pans on the underside of the machine.
2. Tilt the cab up and raise the hood at the rear of the machine.
3. Pressure wash any debris from the engine compartment and chassis area out through the lower opening.

Air Cleaner

The SR 70/80 are equipped with two air filter elements to remove contaminants from the air used for combustion. Regular inspection and replacement is necessary to ensure proper performance and to prolong engine life.

To remove and inspect your air cleaner elements:

1. Turn the engine off.
2. Open the hood at the rear of the machine to gain access to the engine compartment.
3. Locate the black air cleaner enclosure near the top left of the engine compartment (when viewed from the rear).
4. Twist the tension screw (A) counter-clockwise until the band is loose enough to remove the cover, then remove the cover. The primary element (B) should be exposed.
5. Remove the primary element and inspect it. If it appears damaged in any way, replace it. If the element is heavily soiled, replace it. If it appears to be in good condition, clean if necessary and re-install.
6. Once the primary element has been removed, the secondary element (C) should be visible. Remove and inspect it. If the element is damaged or heavily soiled replace it.



Note: The secondary element is not serviceable. It should be replaced after every three cleanings of the primary filter.

Note: The primary element may be cleaned and reused up to five times if properly maintained, but should be replaced at least once a year.

MAINTENANCE

Air Cleaner



7. Once the inspection has been performed, install the new secondary filter element into the enclosure as found upon disassembly.
 8. Install the primary element by sliding it into place in the enclosure as found upon disassembly.
 9. Install and secure the cover by sliding it into place and positioning the band over the retaining lip. Then turn the tension screw clockwise until tight. Gently wiggle the cover to make sure it is secure.
- To clean your primary filter element:
1. Remove loose dirt from the filter element with compressed air or water hose.
Compressed air: 100 P.S.I. max. 1/8" diameter nozzle at least 2" away from filter.
Water: 40 P.S.I. max. without nozzle.
 2. Soak the filter in a non-sudsing detergent solution for at least 15 minutes moving it gently through the solution to further clean the element. (Never soak for more than 24 hours.)
 3. Rinse the filter thoroughly with a gentle stream of water to remove all dirt and remaining detergent.
 4. Allow the filter to dry completely before re-installing it into the machine.



CAUTION

Do not use any heat source other than warm air at less than 160°F to dry the filter.



CAUTION

Do not clean air filter elements while engine warranty is in effect. During the warranty period, ASV recommends replacing air filter elements instead of cleaning them. Heavy-duty air filter manufacturers will not warrant the air filter once it has been cleaned.



Fuel Filter

The fuel filter removes contaminants from the fuel as it enters the engine for combustion. Over time the filter can become plugged and cause the engine to lose power, run roughly or fail to start. The fuel filter should be changed every 500 hours or more often if needed to prevent these conditions from occurring.

To change the fuel filter:

1. Clean the outside of the filter assembly thoroughly to reduce the chances of contaminants being introduced into the fuel system.
2. Twist the water separator catch bowl (A) counter clockwise (when viewed from the bottom) and remove it from the assembly. Take care not to lose the o-ring that seals it to the filter base.
3. Twist the upper lock ring (B) counter clockwise (when viewed from the bottom) and remove it from the assembly.
4. Slide the filter (C) downward to remove it. Note the position of the raised tabs on the upper portion of the filter to simplify reassembly.

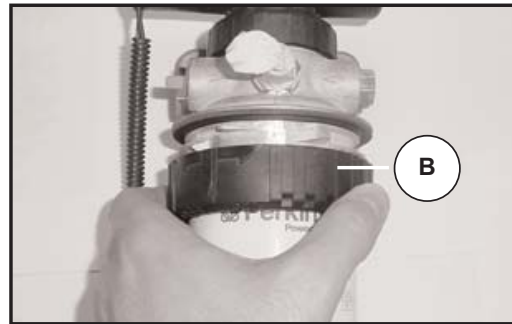

5. Install the new filter element into the assembly by reversing steps 2-4.

Water Separator

The water separator removes water from the fuel supply as the engine runs. Drain the water separator daily to maintain proper function.

To drain the water separator:

1. Loosen the black screw on the bottom of the separator.
2. Re-tighten the screw after the water has been drained from the catch bowl.

MAINTENANCE

Accessory Belts

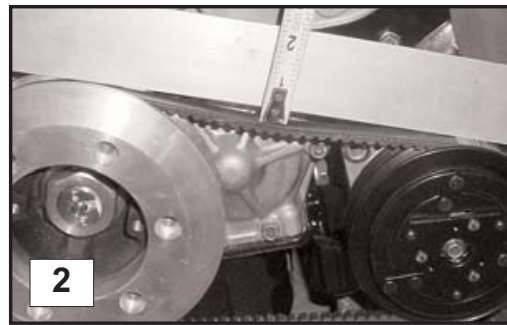
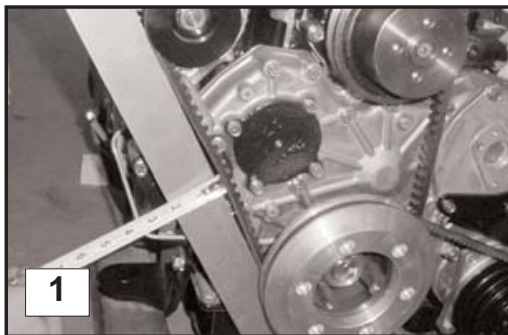

Accessory Belt Tension

Drive belts typically stretch and wear during their service life. The fan and A/C belts should be checked for tension, condition and presence daily prior to operating your machine.

To check fan or A/C belt tension:

1. With the engine cold and off, remove the key from the ignition to avoid accidental start.
2. Lift the hood at the rear of the machine and check to make sure the fan and A/C belts are present and in good condition. If they appear excessively worn, or cracked, replace them.
3. Lay a straight edge across the alternator and crank pulleys (crank and A/C pulleys for A/C belt) and apply a force of 10 lbs. midway between the pulleys. (fig. 1, 2)
4. Measure the distance from the bottom of the straight edge to the top surface of each belt (deflection). Fan belt deflection should measure 3/8" (7/16" A/C) if properly tensioned.
5. If the belts are loose or tight, adjust tension until correct.

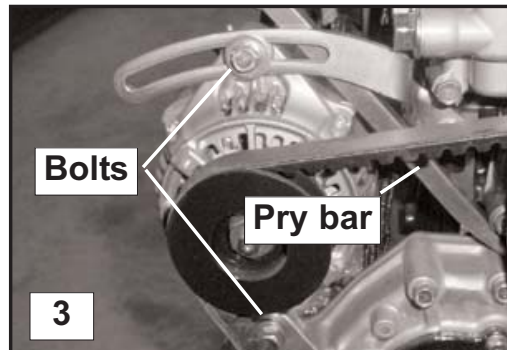

To adjust fan or A/C belt tension:

1. Make sure the engine is cold, off, and the key has been removed from the ignition to avoid accidental start.
2. Lift the hood at the rear of the machine and loosen the bolts securing the alternator or A/C pump slightly to allow the alternator or A/C pump to pivot. (fig. 3, 4)
3. Once loose, use a small pry bar as a lever to force the alternator or A/C pump against the belt(s) to increase belt tension to appropriate level then tighten bolts to specification. (fig. 3, 4)
4. Check the belt tension.
5. Adjust belt tension as necessary until correct.

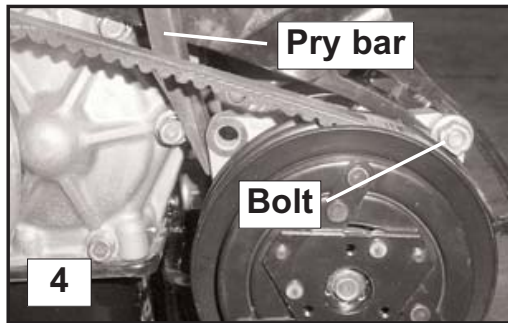

Fan Belt Removal & Installation

To remove the fan belt:

1. Follow steps 1 and 2 of the belt adjustment procedure.
2. Once loose, pivot the alternator towards the engine to increase slack.
3. Then, remove the three bolts securing the fan cage (half) to the fan shroud. Remove that portion of the cage. (fig. 5, 6)
4. Slip the belt off of the engine pulleys and work it around the fan until it is clear of the blades.

To install the fan belt:

1. Reverse the steps of the removal procedure.
2. Perform the belt tension check and adjustment procedures on page 43 to complete the installation.

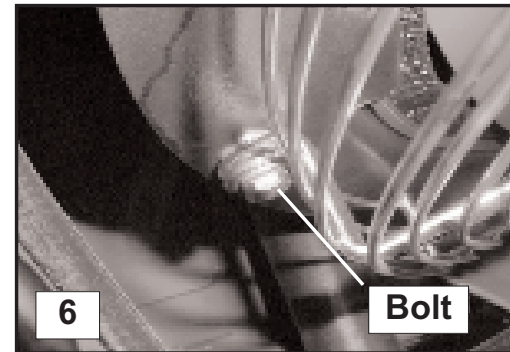
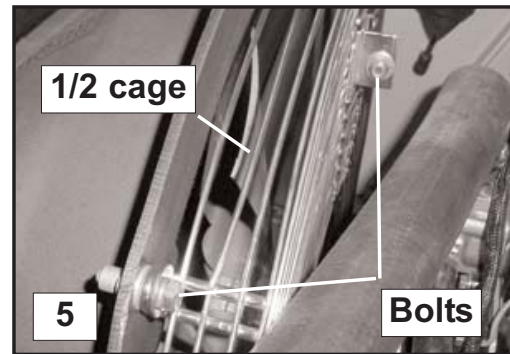

A/C Belt Removal & Installation

To remove the A/C belt:

1. Follow steps 1 and 2 of the belt adjustment procedure.
2. Once loose, pivot the A/C pump towards the engine to increase slack.
3. Slip the belt off of the pulleys and remove it from the machine.

To install the A/C belt:

1. Reverse the steps of the removal procedure to re-install the belt.
2. Perform the belt tension check and adjustment procedures on page 43 to complete the installation.

Engine

Engine Oil/Filter Change

Regular oil changes are necessary to maintain a strong running engine. The normal interval between oil changes is 500 hours or one year. Machines that are operated under harsh conditions should have their oil changed more frequently. ASV recommends oil change intervals of 250 hours or every six months for these machines. Harsh conditions may include: continuous high load applications, operation in high temperatures or abnormally dusty/dirty conditions.

To change the oil and filter:

1. Start and run the engine for a few minutes to warm the oil. Then turn the engine off before proceeding.
2. Remove the rear belly pan beneath the engine.
3. Remove the drain plug from the oil pan and drain the used oil into a suitable catch container. (fig. 1)

Note: Make sure to use the correct size combination or socket wrench to keep the drain plug in reusable condition.

4. Thread the engine oil filter off of the filter head. (fig. 2)
5. Rotate the closed end of the filter towards the engine, position the open end of the filter over the corner of the reservoir, then rotate the filter upward around the reservoir corner to remove. (fig. 2-4)

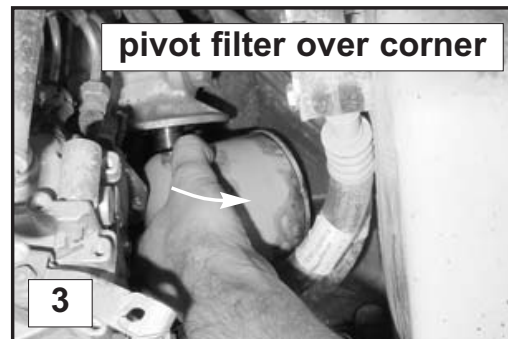
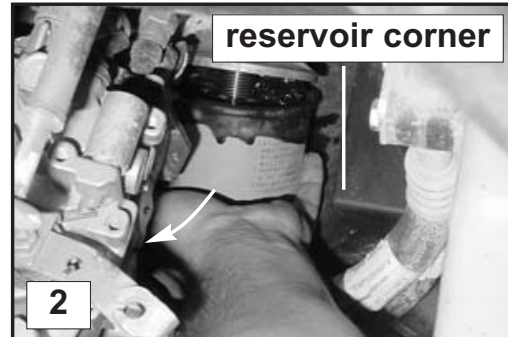

6. Once removed, check to make sure the rubber gasket has come off of the filter head on the old filter. (fig. 5)

**CAUTION**

Caution: If the old filter gasket (A) is not removed from the filter head and the new filter is installed on top of it, an oil leak will result when the engine is started. If unnoticed, the engine can run itself out of oil causing engine failure.



7. Prepare new filter for installation by rubbing fresh oil on the exposed surface of the filter gasket.
8. Thread the new filter onto the filter head. Tighten the filter by hand as instructed by the label located on the filter or filter box.
9. Re-install the oil drain plug into the pan and tighten to 50 +/- 10 lb ft.
10. Remove the oil filler cap and fill the engine crankcase with ASV Posi-Lube™ 10W-30 Heavy Duty Engine Oil (capacity: 9 U.S. quarts including filter). (fig. 6)
11. Install the oil filler cap.
12. Perform a visual inspection to make sure the drain plug, filter and oil filler cap are in place and tight.
13. Start the engine and watch the oil pressure gauge located in the lap bar instrument display. The needle should rise up into the green range as soon as oil pressure has been established. If the needle doesn't rise above the red zone shortly after start-up, turn the engine off immediately and look for potential problems. If the needle does move into the green zone as expected, oil pressure has been achieved.
14. Once the engine is running, perform a visual inspection to make sure there are no leaks or other visible problems.
15. If everything looks like it should, shut the engine down and exit the machine.
16. Re-install the belly pan.
17. Perform the oil level check procedure on page 47.

MAINTENANCE

Engine

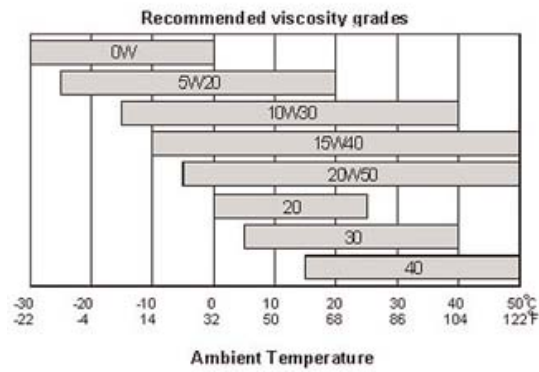

Engine Oil Specifications

ASV recommends using Posi-Lube™ 10W-30 Heavy Duty Engine Oil for most conditions. In the event of an alternate working environment, the chart above may be used as a guide to oil viscosity grades.

You may also use a quality engine oil substitute meeting the following minimum specification:

- API CH-4 multigrade engine oil.

Oil Level Check

To check the oil level:

1. Park the machine on level ground.
2. Open the hood to gain access to the engine compartment.
3. Locate and remove the engine oil dipstick (A) from its tube.
4. Wipe the dipstick with a clean shop cloth and re-insert it into the tube until it comes to rest in its seated position.

5. Remove the dipstick once again and inspect the end for oil on the level indicator.
6. Oil should be present on the dipstick up to, but not over the upper (full) level indicator notch. If the level is correct, re-install the dipstick and then close and latch the hood to complete the procedure.
7. If the level is low, add the proper grade and viscosity engine oil and re-check as necessary until the proper level has been achieved. Then re-install the dipstick and filler cap and close and latch the hood to complete the procedure.

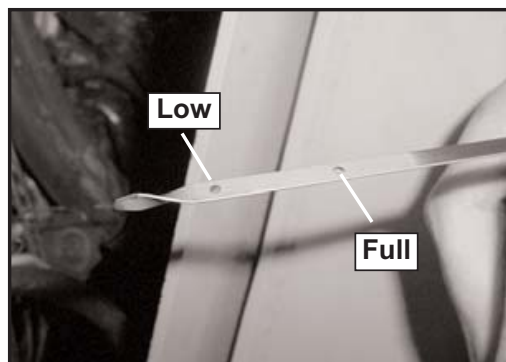
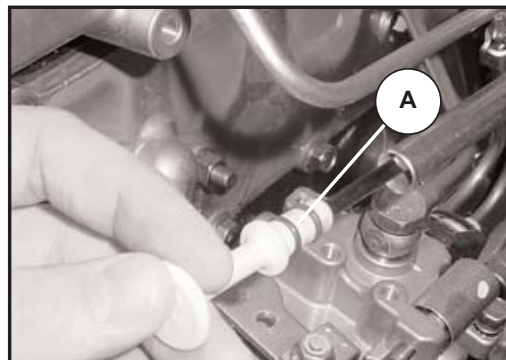

Hydraulic Fluid/Filter Change

Hydrostatic components require extremely clean oil in order to have a long service life. Use extreme caution when changing the hydraulic oil. Introducing dirt or debris could be detrimental to the hydraulic system. ASV recommends service intervals of 500 hours for hydraulic fluid and 250 hours for hydraulic fluid filters.

To change the hydraulic fluid:

1. Locate the hydraulic system drain access situated in the belly pan between the axles on the right side of the machine. (fig. 1)
2. Remove the drain plug using the correct size allen type wrench or allen socket to avoid damaging the drain plug. (fig. 1, 2)
3. Drain the hydraulic fluid into a suitable catch container.
4. Locate the two hydraulic filters underneath the cab on the left side of the machine. (fig. 3)
5. Thoroughly clean around the filters to prevent dirt or debris from entering the system and remove the filters by hand or with a strap as required.
6. Check to make sure the filter gaskets are still present on the old filters. If not, check the filter heads to make sure they are free from old

gasket material prior to installing the new filters.

7. Prepare the new filters by rubbing a small amount of fresh hydraulic oil onto the filter gasket surface and then threading them onto their respective filter heads. Tighten filters by hand as instructed by the label located on the filter or filter box.

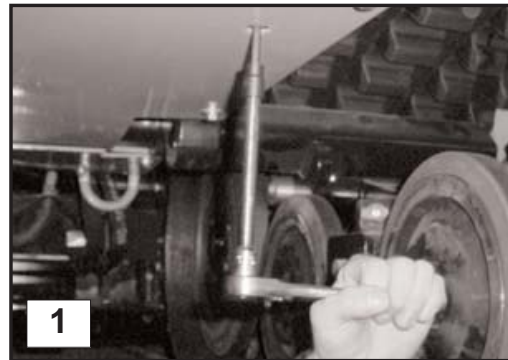

MAINTENANCE

Hydraulic System

8. Install the hydraulic system drain plug and tighten.
9. Remove the hydraulic reservoir filler cap (black) and fill the hydraulic system with ASV Posi-Lube Premium All Season MV Hydraulic Oil or equivalent until the full mark on the hydraulic fluid sight gauge has been reached (approx. 12.5 gal.). (fig. 3, 4)

Note: When checking or adding to the hydraulic fluid level, do so with the lift arms in the lowered position. If the level is checked with the lift arms in the raised position, an inaccurate reading will result.

Note: When adding hydraulic fluid, add fluid slowly until it is visible in the sight gauge. Once visible, add fluid in one quart increments until the full mark has been reached.

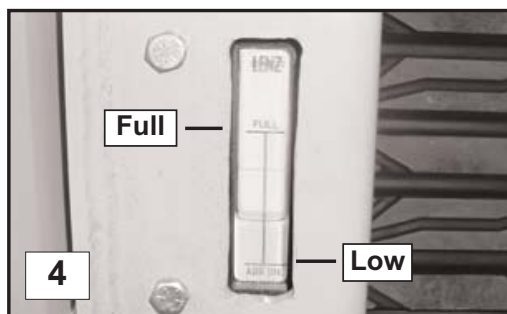

10. Install and secure the hydraulic reservoir filler cap.
11. Start the machine and operate all hydraulic circuits to work any trapped air out of the system.
 - Drive the machine forward and backward.
 - Raise and lower the lift arms (unloaded).
 - Dump and curl bucket/quick attach.
12. Once you have purged the air from the system, check the level on the hydraulic fluid level sight gauge. If the level is low repeat step 9 and 10 to complete the procedure.

Case Drain Filter

The SR machines are also equipped with a filter in the auxiliary circuit case drain line. It protects the main hydraulic system in the event of catastrophic failure in an attachment. This filter is designed to last the life of the vehicle. The only instance where this filter should be replaced is if an attachment equipped with a case drain has a drive motor failure during use. (fig. 5)



Fuse Panel

The electrical systems in the SR machines are equipped with fuses that protect the electrical components from damage. They are located on the fuse panel behind the access cover on the lower right side of the cab interior. (fig. 6)

In the event of an electrical malfunction, the most logical place to start is at the fuse panel. Check the fuse related to the problem you are having and inspect it. If the fuse appears black and burned, it needs to be replaced. Replace fuses with the correct amperage replacement fuse only. Replacing a fuse with one of a lower amperage rating may lead to premature fuse failure. Replacing a fuse with one of a higher amperage rating may burn out the electrical component the fuse was meant to protect. See the troubleshooting section in this manual for an additional resource to aid in tracking suspected electrical problems.



Undercarriages

The undercarriage assemblies in the SR machines typically operate in harsh working conditions. They work in mud, gravel, debris and various other abrasive materials during operation. ASV recommends a daily inspection of the undercarriage assemblies and cleaning if necessary.

Materials that are particularly sticky or abrasive like clay, mud, or gravel should be cleaned from the undercarriages more often to minimize component wear. A pressure washer works well for cleaning materials from the undercarriages. At times when a pressure washer is not available, use a bar, shovel or similar device to remove foreign materials.

When cleaning, pay particular attention to the drive tables, sprockets, and the front and rear wheels where debris is more likely to accumulate. If working in scrap or debris, inspect more often and remove foreign objects that may wrap around or lodge themselves between components causing premature wear and damage.

Operating the SR in loamy sand or on turf or other finished surfaces may require less frequent cleaning, but daily inspection is still advised.

MAINTENANCE

Undercarriages

Track Tension (SR-70/80)

Proper track tension must be maintained for optimal performance and track/undercarriage life. Running a track that is too loose may cause the track to misfeed possibly causing damage to the track and or undercarriage components. Running a track that is too tight may cause track stretch, premature bearing failure, or other preventable damage to the machine. As a rule, a track should only be tightened to the point where there is no visible sag. Never tighten your tracks beyond this point.

Note: During the first 50 hours of operation the tracks will "break-in" and will most likely require adjustment.

To check track tension: (fig. 1, 2)

1. Drive the machine forward 5 feet to remove belt slack from the lower and rearward portions of the track.
2. Lay a straight edge along the top of the track bridging the drive sprocket and front idler wheel.
3. Apply 90 lbs. of down force to the track by either placing weight on top or hanging it using rope or wire midway between the drive sprocket and front idler.
4. Measure from the bottom of the straight edge to the lug surface (top) of the track. The deflection should measure between 3/4" and 1".

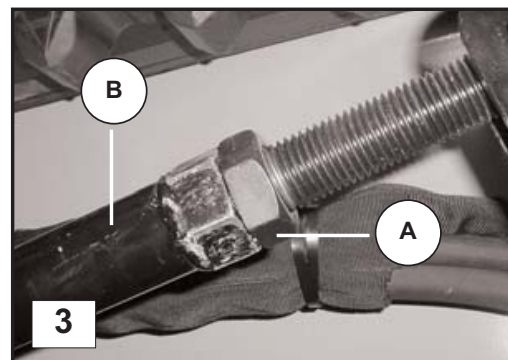
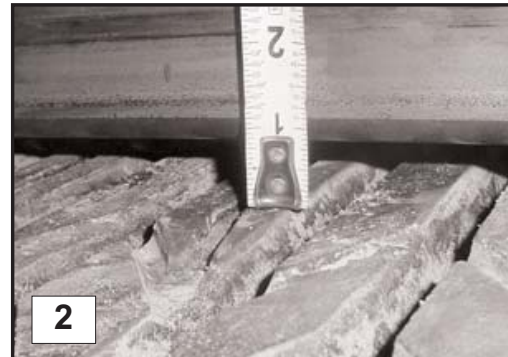
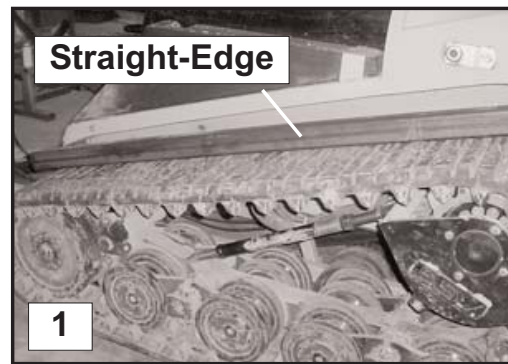

To adjust track tension: (fig. 3)

1. Loosen the lock nut (A) on the turnbuckle (B) and adjust by turning the turnbuckle itself until proper tension has been achieved.
2. Then tighten the turnbuckle lock nut to complete the procedure.
3. Repeat the adjustment procedure on the other side of the machine if necessary.

Track Removal/Installation

Tracks may need to be removed periodically to inspect undercarriage components or for replacement if worn or damaged. This section covers the procedure to remove and install a track on SR 70/80 machines.

Tools required:

- Socket/impact wrench
- Ratchet strap
- Heavy duty hydraulic jack
- Combination wrench
- Long pry bar(s)
- ASV approved jack stands (2)
- Spray lubricant
- Shop vac or Pressure washer

Note: The SR-80 style undercarriage is depicted here. The SR-70 undercarriage is very similar, however it has only one row of stationary inner and outer idler wheels. Track removal is identical with this exception. (fig. 6)

Track Removal

1. Break up and remove any foreign material from the cavity between the suspension rail and the drive table support. (fig. 4)

Note: A shop vac or pressure washer will work well to remove material from this cavity.

2. Clean the threads on the turnbuckle thoroughly using a stiff bristle brush.
3. Loosen the lock nut on the turnbuckle and spin it to the end of the threaded shaft to allow clearance when the drive table is lowered.(fig. 5)

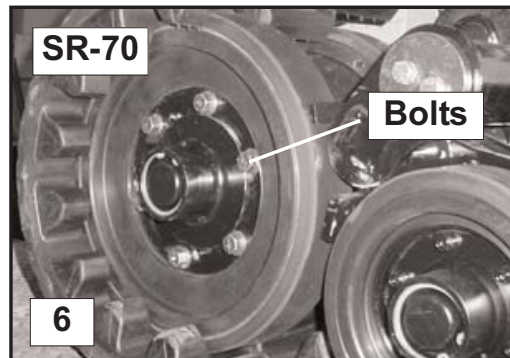

4. Rotate the turnbuckle and lower the drive table as far as it will go.
5. Remove the bolts securing the outer front wheel to the hub. Then remove the wheel. (fig. 6, 7, 8)

MAINTENANCE

Undercarriages

6. Remove the outer scraper plate from the suspension rail. (SR-80 only/fig. 9, 10)
7. Remove the bolts securing the inner wheel to the hub, then remove the wheel. (SR-80 only/fig. 11, 12)
8. Use a pry bar to peel the track over the inner wheel(s) toward the outside of the machine. (fig. 13)
9. Once the track is off of the front wheel(s), pull the rear of the track clear of the suspension. (fig. 14, 15)

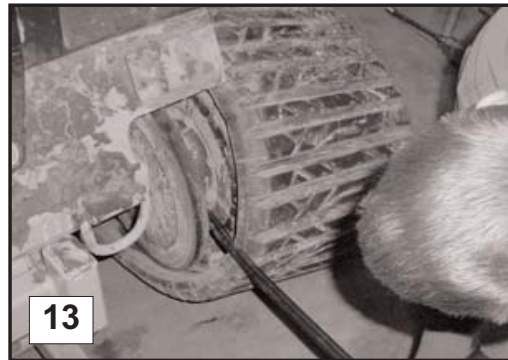
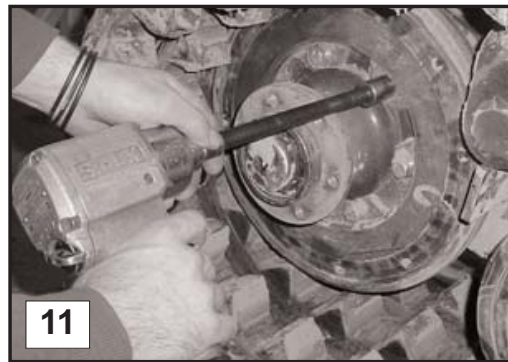

Track Installation

1. Slide the track over the drive sprocket at the rear of the machine. (fig. 1)
2. Slide the front of the track into position for installation.
3. Lubricate the inner front wheel(s) and the inside of the front portion of the track with a spray lubricant.(fig. 2)
4. Attach a ratchet strap to the upper front portion of the track and the other end to one of the tow hooks on the front of the machine. (fig. 3)
5. Tighten the strap until the track is pulled upward slightly and in position to slide over the inner idler wheel(s) at the front. (fig. 3)
6. Pull all of the slack forward and make sure the track drive lugs are properly meshed with the sprocket to provide as much slack as possible for installation.
7. If you have an assistant, have them pull the track forward while you push inward on the track. Work the track over the wheel(s) and into place.
8. If you do not have an assistant, push the track forward in inward in a quick forceful motion to slide the track into place. The ratchet strap will help to keep the track in place while you work it over the idler(s). (fig. 4, 5)



MAINTENANCE

Undercarriages

9. Once the track is in position over the idler wheels, install the inner idler wheel onto the hub and secure it in place with the mounting bolts. Torque them to 90 +/- 10 Lb. Ft. (SR-80 only/fig. 6, 7, 8)

Note: You may need to use a bar to keep the wheel from spinning as you torque the mounting bolts to spec. (fig. 8)

10. Install the scraper onto the suspension rail and tighten the bolts to secure it in place. (SR-80 only/fig. 9)
11. Install the outer idler wheel and secure it in place with the mounting bolts. Torque them to 90 +/- 10 Lb. Ft. (fig. 10, 11)
12. Perform the track tension adjustment and check procedures on page 51 to complete installation.



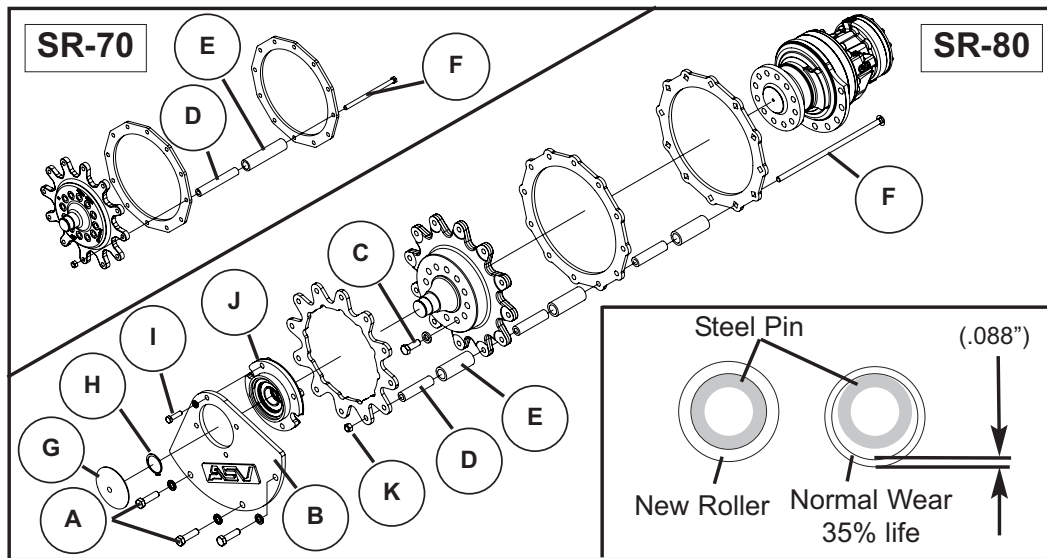

Drive Sprocket Rollers

ASV rubber track loaders utilize rollers on the drive sprockets to drive the track. These rollers help minimize friction between the track and the drive sprocket to prolong track life.

The rollers rotate around hardened steel pins and usually wear on their inside surfaces. As they wear, the rollers become thinner, but will continue to function as long as they rotate freely around the pins. Sprocket rollers should be inspected every 50 hours of operation and replaced if cracked or worn to less than 35% of original thickness. (.088")

To replace worn rollers:

1. Begin by performing steps 1-4 in the track removal procedure on page 52 to allow the sprocket to be removed.
2. Remove the seven bearing plate mounting bolts (A, I), then remove the plate (B) from the drive table.
3. Remove the bearing cap (G) by tapping around the bulged area of the cap with a hammer. This will relieve the outward pressure on the cap and allow for removal.
4. Remove the external snap ring (H) from the bearing shaft.
5. Using a puller, remove the bearing assembly (J) from the shaft.
6. Remove the sprocket mounting bolts (C), then remove the sprocket.
7. Remove one bolt (F) holding the steel pins (D) and rollers (E) in place. Install the new rollers over the pins, then slide the bolt back through the sprocket and pins and secure it with the nut (K).

Note: You may need to pry or lift the track upwards with a hoist above the drive sprocket to provide clearance for removal.

MAINTENANCE

Undercarriages

8. Repeat this process as required throughout the sprocket.
9. Reinstall the sprocket by reversing steps 2-6.

Note: During removal of the bearing cap (step 3) the bulged area of the cap is beaten inward. When reinstalling, orient the cap so that the domed area is facing outward. Then tap the center of the cap with a ball peen hammer or similar device to reset the cap. Do this gently. Too much inward force can damage (mushroom) the bearing shaft.

10. Repeat steps 1-9 on the other side of the machine if necessary.
11. Perform the track tension adjustment and check procedures on page 51.

Note: Replace rollers as a set to simplify inspection and maintain proper sprocket function.

TROUBLESHOOTING - CONTENTS

Overview/No-Start	59
Hydraulics	60
Electrical	61
Overheat.....	62

Troubleshooting

Overview/No-Start

Overview

The most effective way to prevent a malfunction from occurring is to closely follow the recommended maintenance schedule and instructions throughout the life of the machine. However, if a malfunction does occur, finding the problem and fixing it quickly are important. This section covers a select set of symptoms that may occur and suggests possible causes.

Problem

Machine will not crank over.

Possible causes:

1. Continuous high flow switch activated.
2. Continuous low flow switch activated.
3. Power quick-attach switch in unlocked position. (SR-80)
4. Battery cables loose or corroded.
5. Ignition fuse blown.
6. Main starter fuse blown.
7. Starter relay malfunctioning.
8. Weak or dead battery.
9. Faulty continuous hydraulic flow or power quick attach-switch.
10. Faulty ignition switch.
11. Faulty starter.
12. Loose, broken or disconnected wiring at key, relay or starter.
13. Main power fuse (60/80 amp) blown.

Problem

Machine cranks, but will not start.

Possible causes:

1. Fuel tank empty, fuel filter plugged or fuel line restricted.
2. Battery discharged (engine rotates slowly).
3. Injection pump fuse blown.
4. Power relay (B) fuse blown. (40 amp)
5. Faulty power relay (B).
6. Loose, broken or disconnected wiring at injection pump or fuse.
7. Glow plugs not pre-heating (look for black smoke).
 - a) Main glow plug fuse blown.
 - b) Glow plug relay malfunctioning.
 - c) Loose, broken, or disconnected wiring at ignition switch, relay or glow plug ground strip.
 - d) Faulty glow plugs.
8. Faulty ignition switch.
9. Loose, broken or disconnected wiring in starting circuit.
10. Loose, broken or disconnected wiring at fuel shutdown solenoid.
11. Air in fuel system, or defective fuel injection pump.

Problem

Machine starts, but hydraulics will not operate.

Possible causes:

1. Operator not in seat.
2. Seat belt not fastened.
3. Safety relay fuse and or safety solenoid fuse for seat belt and operator presence safety switches blown.
4. Faulty operator presence safety switch.
 - a) Test for continuity through operator presence and seat belt switches. Adjust or replace as necessary.
5. Loose, broken or disconnected ground wires (check ground connections behind operator seat, from cab to chassis, and on the chassis crossmember.)
6. Faulty safety relay.
7. Faulty safety solenoid or safety solenoid spool.
8. Loose, broken or disconnected wiring at fuse, relay, or safety solenoid.
9. Low charge pressure.

Problem

Lift arm/bucket controls are operational, but tracks will not move.

Possible causes:

1. Leak in feed line to drive control joystick (pilot control).
2. Loose, broken or disconnected wire to DA control solenoid.

3. Drive control joystick (pilot control) malfunction.
4. Low charge pressure.
5. Parking brake switch in on position.
6. Faulty parking brake switch.

Problem

Tracks are operational, but lift arms will not move.

Possible causes:

1. Continuous hydraulic flow switch activated, sending oil over relief (lift arms work, but move slowly).

If auxiliary flow hydraulics work check for:

- a) Leak in feed line to lift arm control joystick (pilot control).
- b) Lift arm control joystick (pilot control) malfunction.
- c) Hydraulic control valve assembly malfunction.

If auxiliary flow hydraulics do not work check for:

- a) Main auxiliary relief malfunction.
- b) Faulty auxiliary pump.

Troubleshooting

Hydraulics/Electrical

Problem

Lift arms are operational, but high/low flow auxiliary circuits are not.

Possible causes:

1. Auxiliary hydraulic fuse blown.
2. Faulty ground at chassis crossmember.
3. Faulty auxiliary hydraulic switch.
4. Faulty auxiliary hydraulic solenoid at pilot generation block.
5. Loose, broken or disconnected wire at fuse, auxiliary hydraulic switch, or pin connector P10.
6. Auxiliary hydraulic pilot generation spool stuck in closed position.
7. Faulty or improperly connected quick coupler.
8. Quick coupler block pressure release stuck in down (open) position.

Problem

Lift arms will not float, engine labors and lift arms create down pressure when float is engaged.

Possible causes:

1. Engine RPM too low.
2. Low charge pressure.
3. Lift arm control joystick malfunction (pilot control).
4. Hydraulic control valve assembly malfunctioning.

Problem

Lift arm control joystick will not lock into float position.

Possible causes:

1. Float magnet fuse blown.
2. Loose, broken, or disconnected wiring at fuse, float detent magnet, or pin connector P8.
3. Faulty float detent magnet.

Problem

Multiple switches/electrical accessories are not operational in ON or RUN position.

Possible causes:

1. Power A or B fuse(s) blown.
2. Faulty power relay (A or B).
3. Faulty ignition switch.
4. Loose, broken or disconnected wiring at ignition switch, fuse or relay.

Problem

Battery will not charge/maintain charge.

Possible causes:

1. Loose alternator belt.
2. Alternator fuse blown.
3. Faulty alternator diode.
4. Loose, broken or disconnected wiring at battery, alternator, diode or fuse.
5. Excessive current draw with key in "off" position.
6. Faulty battery.
7. Faulty alternator.

Problem

Hydraulic oil temp. elevated; hydraulic system overheating.

Possible causes:

1. Debris plugging oil cooler, limiting airflow.
2. Low hydraulic oil level.
3. Loose or missing fan belt.
4. Damaged or missing cooling fan blades.
5. Incompatible attachment.
 - a) Attachment must match machine flow capabilities.
 - b) Attachment hose inside diameter must be at least 1/2" for low flow and 3/4" for high flow.
 - c) Low flow attachment coupled to high flow circuit.
6. Faulty hydraulic oil temperature sending unit.
7. Faulty quick coupler.
8. Cooler bypass relief open.

Note: Cooler bypass should open at 80 PSI.

Problem

Engine coolant temperature elevated; engine overheating.

Possible causes:

1. Low coolant level.
2. Debris plugging radiator, limiting airflow.
3. Damaged or missing cooling fan blades.
4. Loose or missing fan belt.
5. Faulty engine coolant temperature gauge.

MACHINE SPECIFICATIONS

General Dimensions

	SR-80	SR-70
Machine width:	72 in. / 1,829 mm	66 in. / 1,676 mm
Ground clearance:	15 in. / 381 mm	15 in. / 381 mm
Max. lift height, at hinge pin:	125 in. / 3,175 mm	125 in. / 3,175 mm
Machine length, w/out bucket:	112 in. / 2,845 mm	112 in. / 2,845 mm
Machine length, with bucket:	142 in. / 3,607 mm	141 in. / 3,581 mm
Height to top of ROPS:	86 in. / 2,184 mm	86 in. / 2,184 mm

Track Specifications

Track width:	20 in. / 508 mm	15 in. / 381 mm
Length of track on ground:	71 in. / 1,803 mm	71 in. / 1,803 mm
Ground contact area:	2,840 in.2 / 1.83 m2	2,130 in.2 / 1.37 m2

Machine Weight

**Operating weight with bucket:	8,972 lb / 4,070 kg	7,890 lb / 3,579 kg
Shipping weight without bucket:	8,060 lb / 3,656 kg	7,315 lb / 3,318 kg
**Ground pressure:	3.15 psi / 21.7 kPa	3.70 psi / 25.51 kPa

Engine

Model:	Perkins 804C-33T	Perkins 804C-33T
Type:	4-cylinder diesel, turbo	4-cylinder diesel, turbo
Displacement:	201.4 in.3/3.3 liter	201.4 in.3/3.3 liter
Gross HP @ 2800 rpm:	80.5 hp / 60 kW	71 hp / 53 kW
Torque (peak):	186 ft-lb / 253 Nm	173 ft-lb / 234 Nm

Operating Specifications

Operating capacities:		
*Tipping load:	6,200 lb / 2,812 kg	5,500 lb / 2,495 kg
*35% tip load:	2,170 lb / 984 kg	1,925 lb / 873 kg
*50% tip load:	3,100 lb / 1,406 kg	2,750 lb / 1,247 kg
Maximum speed low (high) range:	7(12.5) mph / 12.5(20) kmh	8 mph / (12.9) kmh

Auxiliary Hydraulic Pump

Low flow, max.:	20 gpm / 75.7 lpm	20 gpm / 75.7 lpm
High flow, max.:	30 gpm / 113.6 lpm	30 gpm / 113.6 lpm
Pressure:	3,000 psi / 20,670 kPa	3,000 psi / 20,670 kPa

Service Refill Capacities

Fuel tank:	18 gal / 68 L	18 gal / 68 L
(Dry system: 21 gal.) ***Hydraulic tank:	12.25 gal / 46.4 L	12.25 gal / 46.4 L
***Engine coolant:	3 gal / 12 L	3 gal / 12 L
***Engine oil, including filter:	9 qt / 8.52 L	9 qt / 8.52 L

Specifications are subject to change without notice.

* SAE J818 standards define operating capacities of rubber-tired skid steers (50% tipping load) and tracked loaders (35% tipping load). There are no standards defining the operating capacity of machines equipped with a suspended undercarriage or machines with rubber tracks.

** Bucket installed, fluid levels full, 165 lb. operator seated in cab.

*** When replacing or replenishing fluids, it is recommended that you specify genuine ASV Posi-Lube™ products from your ASV dealer.

LIMITED WARRANTY

The warranty herein set forth applies solely to the ASV Rubber Track Loaders manufactured by ASV, Inc. and is in lieu of all other warranties, expressed or implied. No person, agent, or dealer is authorized or empowered to give any other warranty or to assume other liability on behalf of ASV, Inc. Warranty of ASV Rubber Track Loaders is extended to the original purchaser, however, the balance of the unused warranty may be transferred to a second party.

ASV Inc. warrants only the products it manufactures or sells and does not warrant that other products will function properly or will not cause damage when used on an Rubber Track Loader. ASV does not assume liability for indirect, incidental or consequential damages.

ASV will repair or replace, free of charge to the holder of the warranty, any parts defective in material or workmanship under normal use and service and related labor charges. Warranty work must be performed by the selling ASV authorized dealer or agent. The owner is responsible for getting the machine to that selling authorized dealer or agent. ASV will not reimburse transportation, rental or inconvenience costs. ASV reserves the right to inspect the part prior to any decision involving a warranty claim. In no case shall ASV grant a remedy that exceeds the purchase price of the component or part.

The warranty validation form should be completed at the time of purchase by the dealer and customer. This form should be sent to ASV Inc. by the dealer (by mail or at www.asvi.com) as soon as possible to prevent any delays in warranty claims.

The warranty periods are as follows:

1. For Rubber Track Loaders purchased by a retail customer: One year from date of purchase, with no hour limit.
2. Machines purchased for rental: One year from date of first rental, with no hour limit.
3. Six months from date of sale on batteries, and 50% exchange on remaining six months.
4. Ninety days from date of sale on dealer installed parts and accessories.
5. Engine: warranty for the Perkins diesel engine is separate from ASV Inc's warranty and is described in the separate engine warranty information.
6. Original rubber tracks are covered by a warranty period of 24 months or 1,000 operating hours, whichever occurs first, starting from date of delivery to the first user; tracks are pro-rated after the first 300 hours.

The following will VOID the warranty:

- a. Failure to perform proper maintenance, service, or operating procedures as recommended in the Operators Manual.
- b. Repair by anyone other than an authorized ASV dealer or agent.
- c. Use of improper hydraulic fluid.
- d. Misuse, abuse, neglect, or improper adjustment, accident, or improper application.
- e. Any modification or removal of parts, unless authorized by ASV, Inc.
- f. Removal or mutilation of the Product Identification Number (PIN).
- g. Exceeding the G.V.W. of the machine.

No other warranty or guarantee of any kind is made by ASV, Inc. expressed or implied, statutory, by operation or law, or otherwise, including merchantability and fitness for a particular purpose.

STANDARD TORQUE GUIDELINES

Inch Fasteners

Thread size	Standard Torque
1/4"	9 +/- 2 lb ft
5/16"	18 +/- 4 lb ft
3/8"	35 +/- 7lb ft
7/16"	50 +/- 11 lb ft
1/2"	75 +/- 15 lb ft
9/16"	120 +/- 22 lb ft
5/8"	160 +/- 30 lb ft
3/4"	275 +/- 37 lb ft
7/8"	460 +/- 60 lb ft
1"	660 +/- 75 lb ft
1-1/8"	960 +/- 110 lb ft
1-1/4"	1320 +/- 150 lb ft
1-3/8"	1780 +/- 220 lb ft
1-1/2"	2280 +/- 260 lb ft

Metric Fasteners

Thread size	Standard Torque
M6	12 +/- 3 Nm
M8	28 +/- 7 Nm
M10	55 +/- 10 Nm
M12	100 +/- 20 Nm
M14	160 +/- 30 Nm
M16	240 +/- 40 Nm
M20	460 +/- 60 Nm
M24	800 +/- 100 Nm
M30	1600 +/- 200 Nm
M36	2700 +/- 300 Nm

Machine Specific Fasteners

Drive Sprocket Roller Bolts/Nuts

Torque to: 80 +/- 10 Ft./Lbs.

Drive Sprocket Retaining Bolts

Torque to: 180 +/- 10 Ft./Lbs

When replacing or replenishing the fluids and lubricants in your ASV Rubber Track Loader, you can specify ASV Posi-Lube products. This ensures that the new fluids and lubricants match those originally installed when your machine left the ASV factory. Posi-Lube products were developed for, tested and approved by ASV to assure optimum life and performance in all ASV Rubber Track Equipment, when used as recommended.

The ASV Posi-Lube product line includes:

- Heavy Duty Engine Oil, 10W-30
- Premium All Season MV Hydraulic Oil
- Multi-Purpose EP Lithium Grease
- Long-Life 50/50 Antifreeze/Coolant
- Undercarriage Wheel Bearing Lubricant.

Posi-Lube fluids and lubricants are available through your ASV Dealer. If Posi-Lube products are not available, use high quality substitutions that meet or exceed the specifications listed above and throughout this manual.

Fuel Specifications

In North America, diesel fuel, distilled from crude oil, identified as No. 1-D or No. 2-D in "ASTM D975" generally meet machine requirements.



ASV Inc.

840 Lily Lane
P.O. Box 5160
Grand Rapids, MN 55744

ASV Parts & Service

Phone: 1-800-346-4367

Fax: 1-218-327-2297

Internet: www.asvi.com



ASVSR10M-02 (9/06)
Copyright 2006 ASV Inc.